

English

2-Wire Video Outdoor Station

User Manual

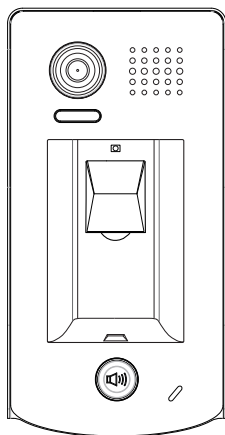

DT601/FP

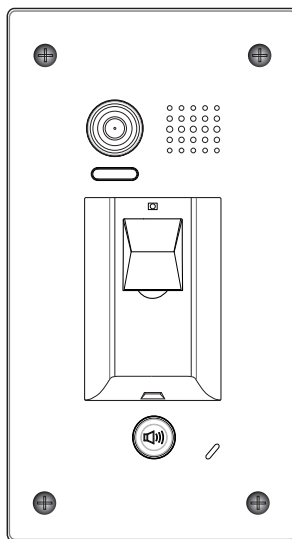

DT601F/FP

1.Parts and Functions

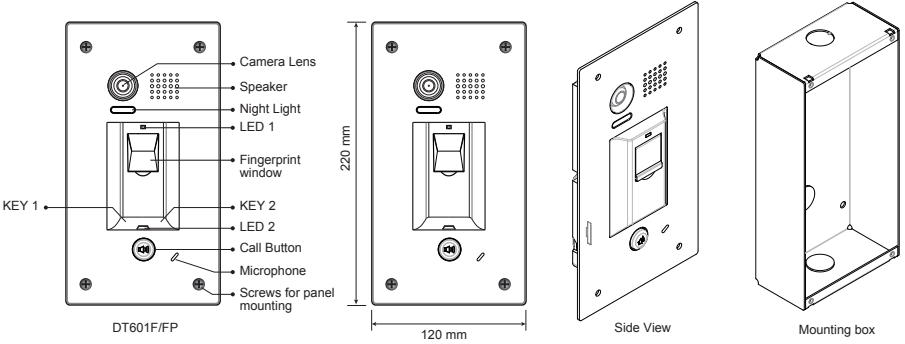
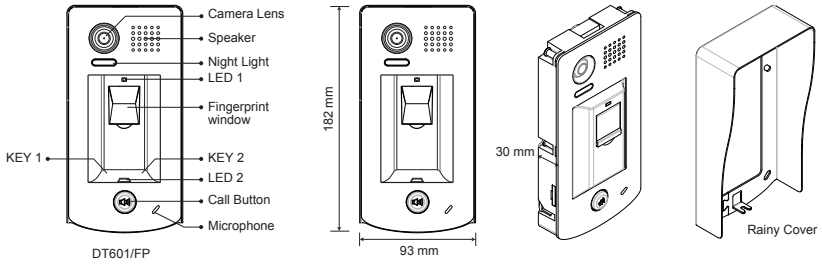

2.Terminal Descriptions

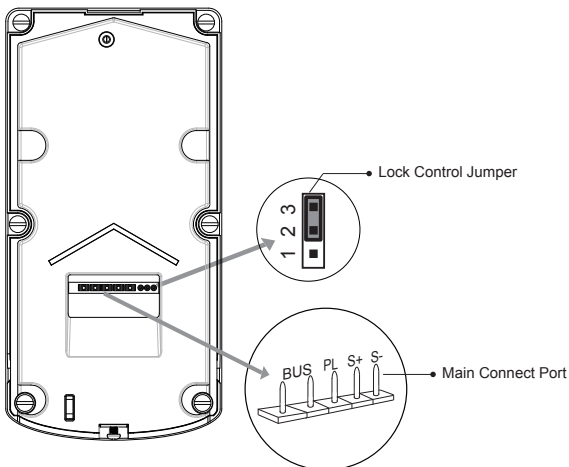

- **Lock Control Jumper:** To select the lock type.
- **Main Connect Port:** To connect the bus line and the electronic locks.
- **BUS:** Connect to the bus line, no polarity.
- **PL:** External lock power input, connect to the power positive(power +).
- **S+:** Lock power(+) output.
- **S-:** Lock power(-) output, connect to the power(-) input of locks(only when using the door station to power the locks, if using the external power supply for the locks, the S- will not be connected).

3. Door Station Mounting

3.1 DT601/FP Mounting

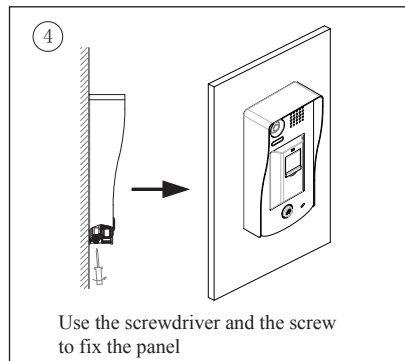
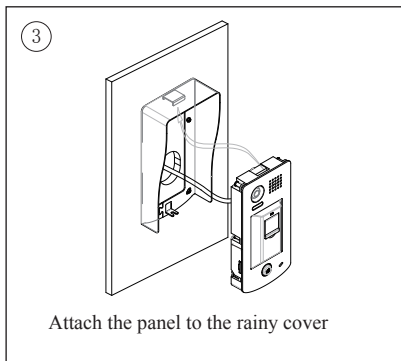
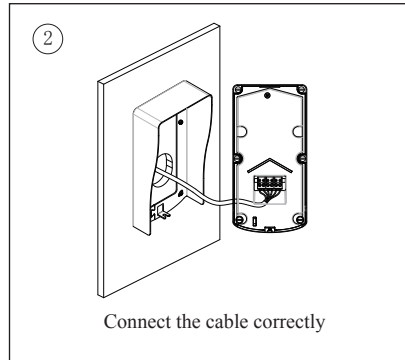
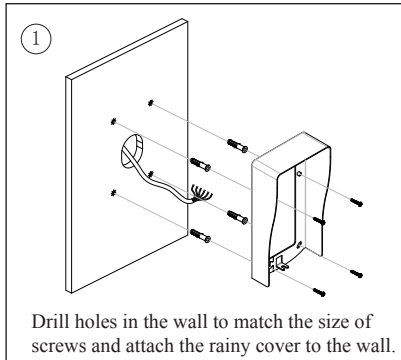

3.2 DT601F/FP Mounting

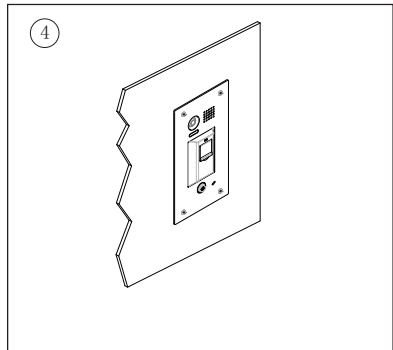
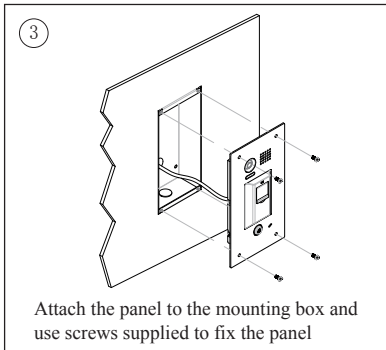
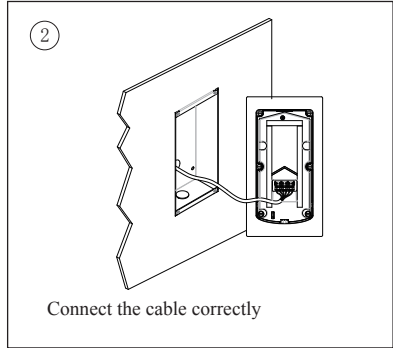
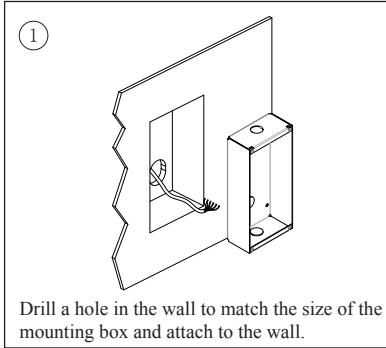

4. System Wiring and Electric Lock Connection

4.1 Basic Connection

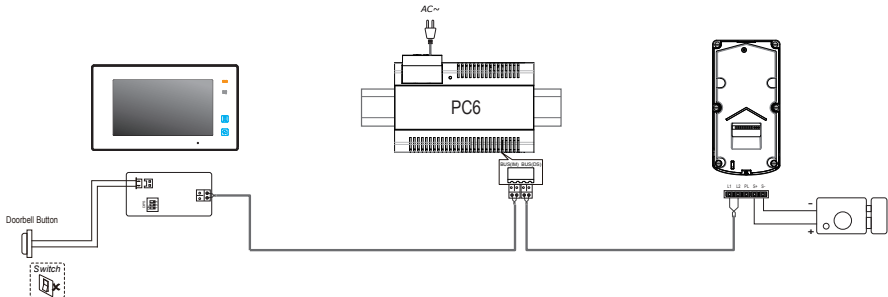

4.2 Electric Lock Connection

4.2.1 Door Lock Controlled with Internal Power

Note:

1. Electronic lock of Power-on-to-unlock type should be used.
2. The door lock is limited to 12V, and holding current must be less than 250mA.
3. The door lock control is not timed from Exit Button(EB).
4. The **Unlock Mode** Parameter of Monitor must be set to 0 (by default).

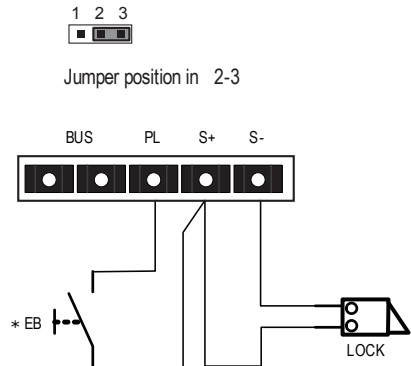

4.2.2 Door Lock Controlled with Dry Contact

Note:

1. The external power supply must be used according to the lock.
2. The inside relay contact is restricted to AC or DC 24V/1A.
3. The jumper must be taken off before connecting.
4. Setup the **Unlock Mode** of Monitor for different lock types.
 - Power-on-to-unlock type:Unlock Mode=0 (by default)
 - Power-off-to-unlock type:Unlock Mode=1

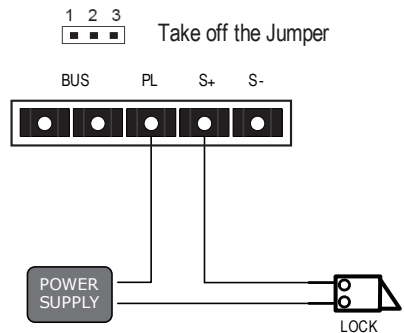

4.3 Unlock parameter setting(set on monitor)

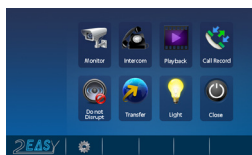

1.Touch **EASY** icon on main menu page.



2.Touch **UNLOCK** button and hold for 2s.

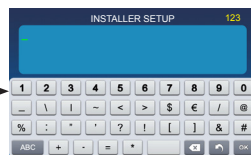

3.A digital keypad will be shown.

Note:

- 1.must connect DT601(F)/FP correctly before setting.
- 2.the parameter will be saved in DT601(F)/FP automatically,so you need only set on one monitor.
- 3.Here we take DT47M(the monitor) for example, please refer to the corresponding user manual.

4.4 Multi Door Stations Connection

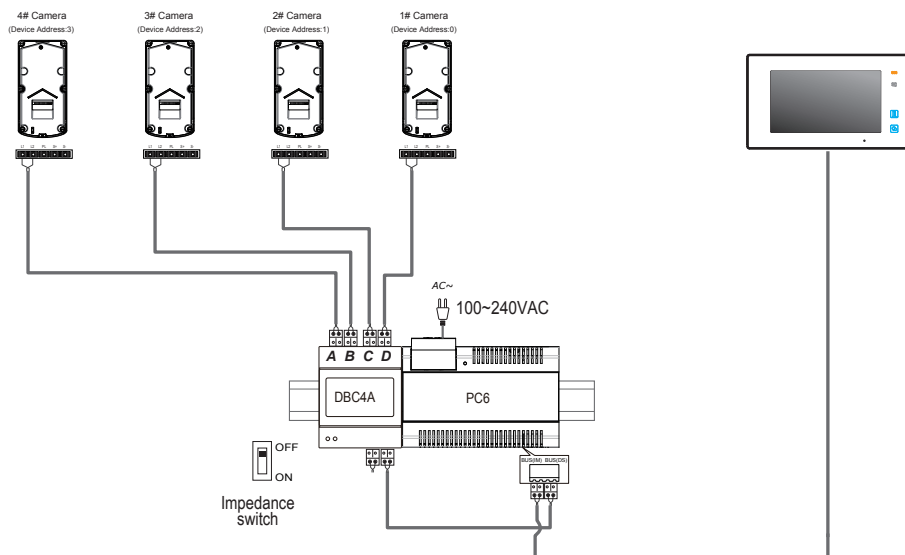

4.5 Multi Monitors Connection

4.5.1 Basic IN-OUT Wiring Mode

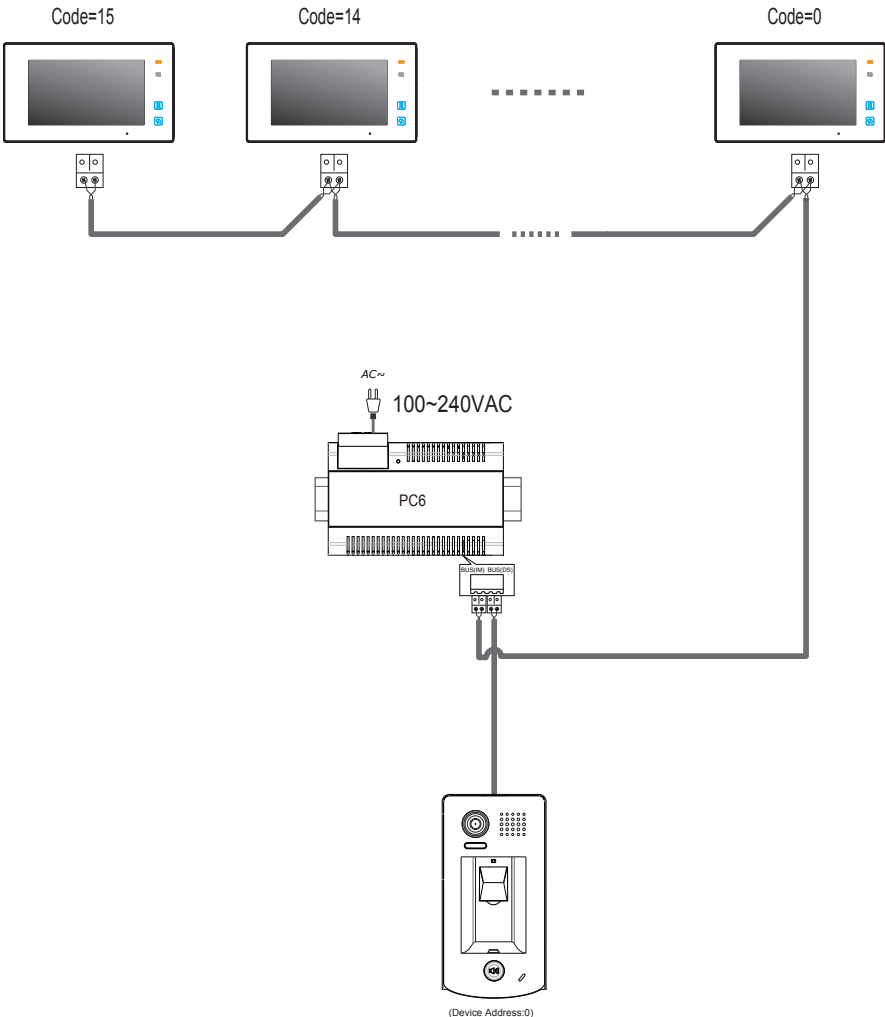

NOTE: Here we take DT47M(the monitor) for example.

4.5.2 With DBC4A Wiring Mode

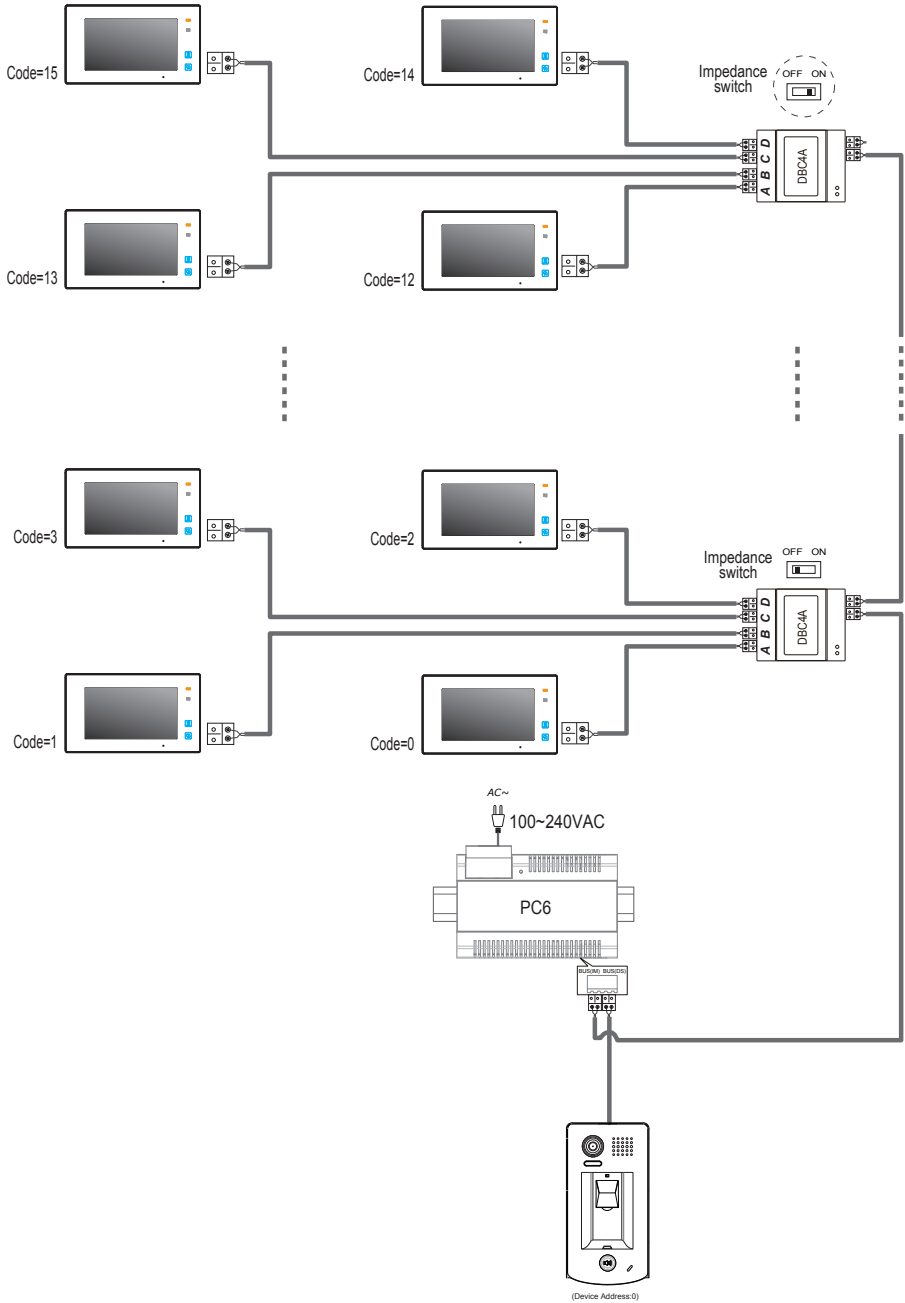

NOTE: Here we take DT47M (the monitor) for example.

5. Setup

5.1 ID of Doorstation Settings

The ID of doorstation can be set to ID0/ID1/ID2/ID3. The default is ID0.

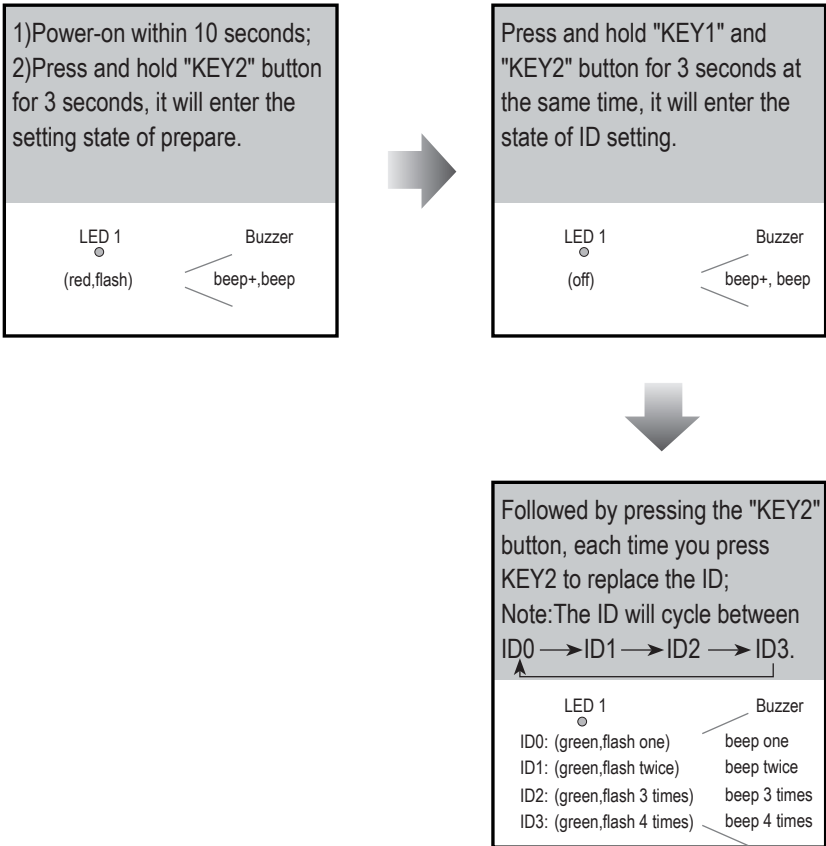

Note: In all steps, if there isn't any operation within 10s, or press Call button, it will exit the setting, and the color of LED1 turns to red, and the buzzer sounds "beep, beep+".

5.2 Unlock Time Settings

The unlock time can be set to 1~30 seconds. The default is 1s.

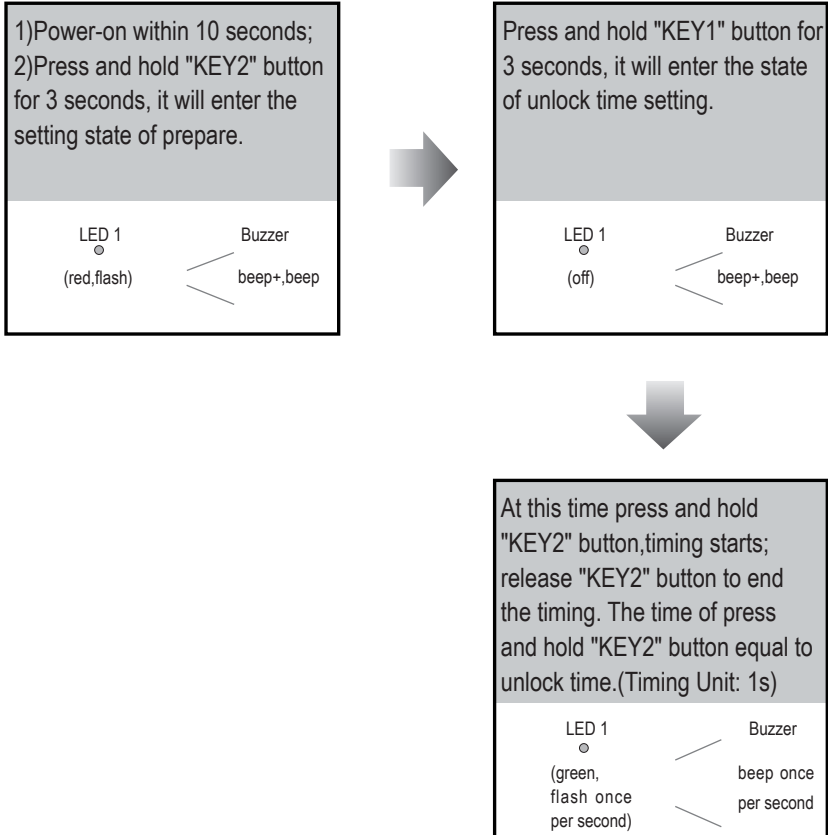

Note: In all steps, if there isn't any operation within 10s, or press Call button, it will exit the setting, and the color of LED1 turns to red, and the buzzer sounds "beep, beep+".

5.3 Ringtone Mode Settings

The system supports three ringtone modes: [A]one ringtone, [B] continuous ringtone, [C]forbid ringtone. The default is one ringtone.

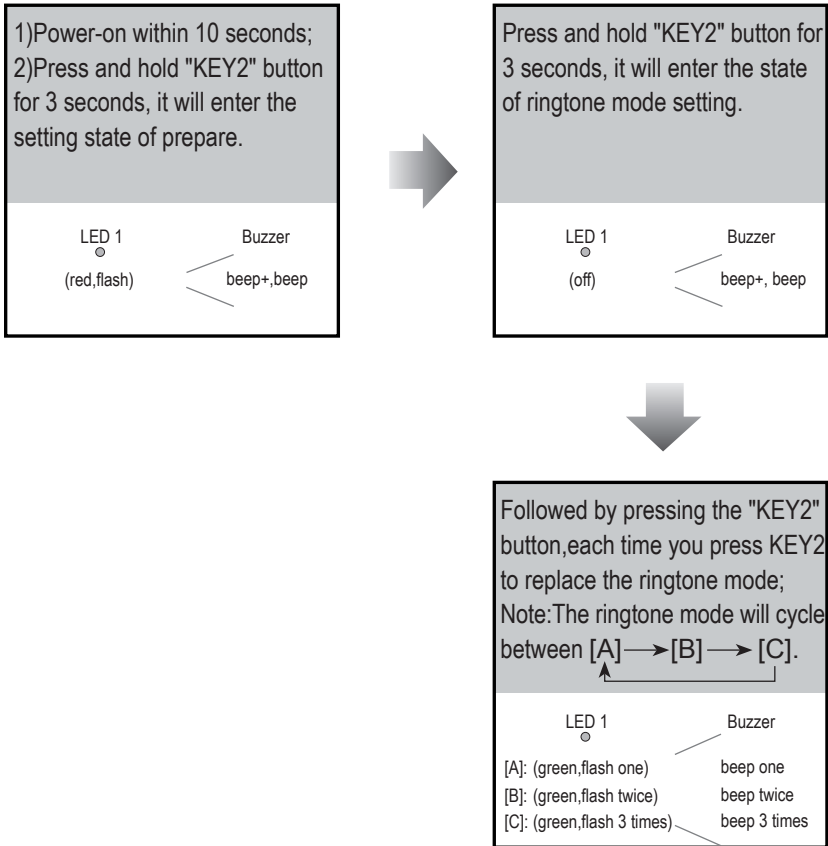

Note: In all steps, if there isn't any operation within 10s, or press Call button, it will exit the setting, and the color of LED1 turns to red, and the buzzer sounds "beep, beep+".

6. Register [Management Fingerprint]

[Management Fingerprint] will serve as a registered or delete credential of user fingerprint. The system can only store a management fingerprint.

6.1 Register [Management Fingerprint]

When the system has never been registered [Management Fingerprint], you can according to the following operation to register [Management Fingerprint].

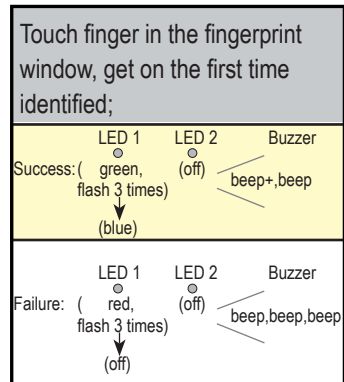
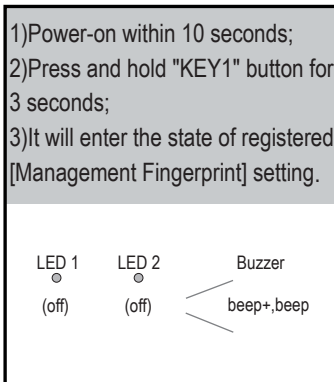

Note: 1) In the second identified, when it succeeded, the system will exit the setting, then return to the standby state; When it failed, the system will return to the operation of first identified.

2) In all steps, if there isn't any operation within 10s, or press Call button, it will exit the setting, and the color of LED1 turns to red, and the buzzer sounds "beep, beep+".

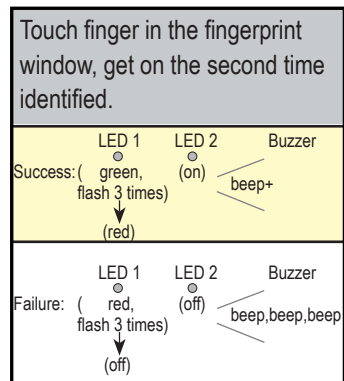

6.2 Update [Management fingerprint]

When the system has been registered [Management Fingerprint], you can according to the following operation to register new [Management Fingerprint].

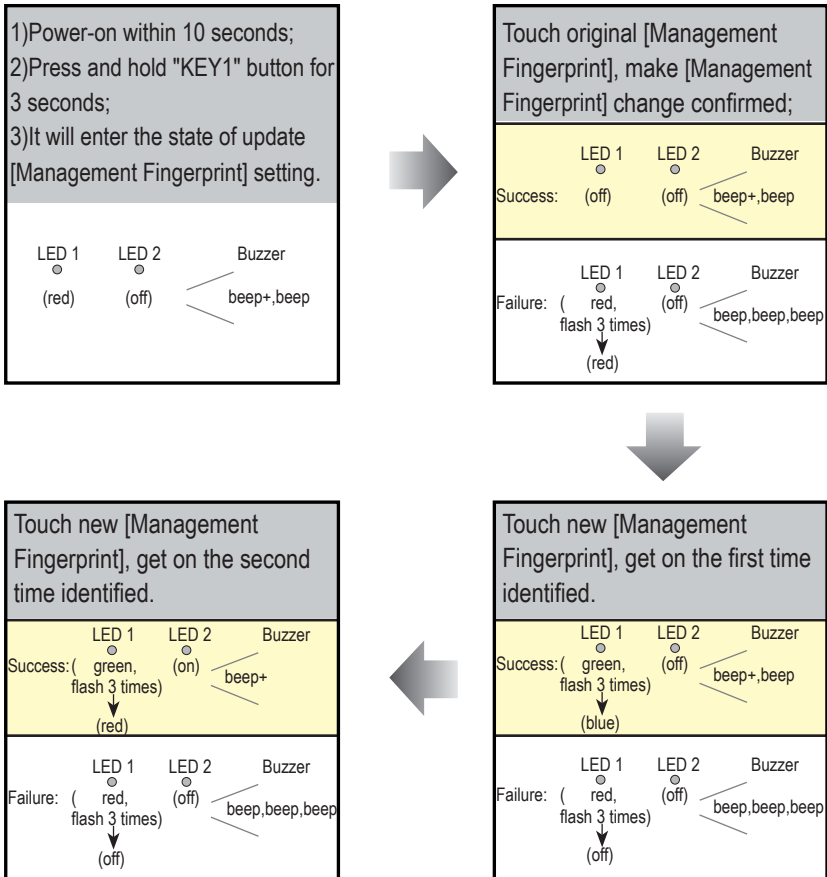

Note:

1) In the second identified, when it succeeded, the system will exit the setting, then return to the standby state; When it failed, the system will return to the operation of first identified.

2) In all steps, if there isn't any operation within 10s, or press Call button, it will exit the setting, and the color of LED1 turns to red, and the buzzer sounds "beep, beep+".

7. Register User Fingerprints

User fingerprints will serve as a unlock credential for user. The system can store 200 user fingerprints.

7.1 Add User Fingerprints

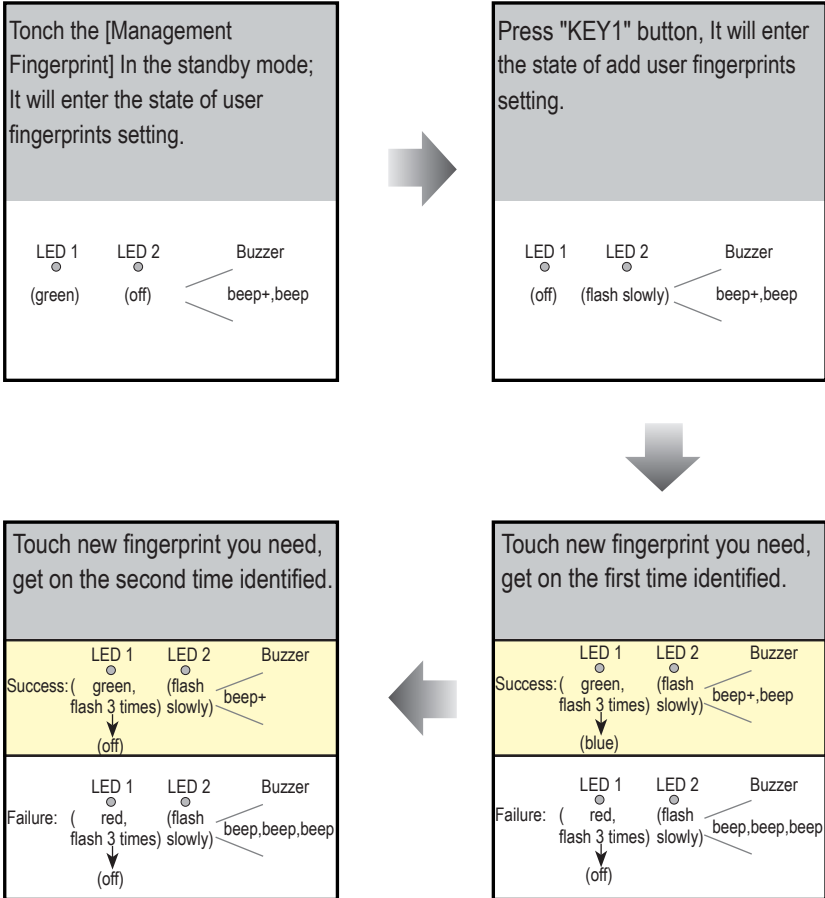

Note:

- 1)In the second identified, regardless of success or failure, the system will return to the operation of first identified, you can continue to add new fingerprint;
- 2)In all steps, if there isn't any operation within 10s, or press Call button, it will exit the setting, and the color of LED1 turns to red, and the buzzer sounds "beep, beep+".

8. Precautions

- Please clean the unit with soft cotton cloth, don't use the organic impregnant or chemical clean agent. If necessary, please use a little pure water or dilute soap water to clean the dust.
- The unit is weather resistant. However do not spray high pressure water on access control keypad directly. Excessive moisture may cause problems with the unit.
- You must use the right adaptor which is supplied by the manufacture or approved by the manufacture.
- Pay attention to the high voltage inside the products, please refer service only to a trained and qualified professional.

9. Specifications

- Power Supply : DC 24V ;
- Power Consumption: Standby 34mA; Working status 158mA;
- Camera: Color ARS; 500 TV Lines;
- Lock Power supply: 12Vdc, 280mA(Internal Power);
- Mounting: Surface mounting(DT601/FP)
Flush mounting (DT601F/FP)
- Working temperature: -15°C ~ +55°C
- Wiring: 2 wires,non-polarity
- Dimension: 182(H)×93(W)×44(D)mm(DT601/FP)
220(H)×120(W)×50(D)mm(DT601F/FP)

10. Cables Requirements

The maximum distance of the wiring is limited in the DT system. Using different cables may also affect the maximum distance which the system can reach.

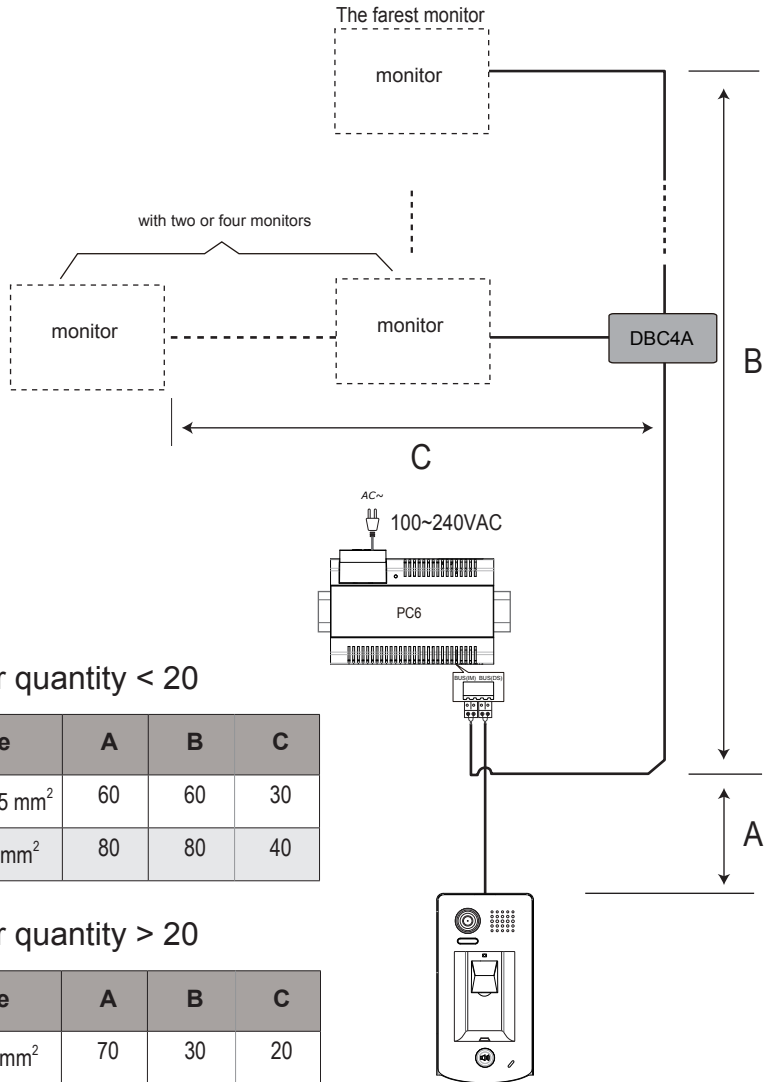

When Monitor quantity < 20

Cable Usage	A	B	C
Twisted cable 2x0.75 mm ²	60	60	30
Twisted cable 2x1 mm ²	80	80	40

When Monitor quantity > 20

Cable Usage	A	B	C
Twisted cable 2x1 mm ²	70	30	20
Twisted cable 2x1.5 mm ²	70	50	30

Note: If the monitor has been specified the distance, refer to the parameter.

The design and specifications can be modified without notice to the user. Right to interpret and copyright of this manual are reserved.