

# IP 2-wire System

Technical Guide

**IP network for DT System**

# Chapter 1

1.1. IP System Description

1.2. IP System Part List

1.3. IP System Feature

1.4. IP System Typical Applications

1.5. Wiring Diagrams

1.5. 1 Connect with PC in single family system

1.5. 2 Connect Common Door Station in Apartment compound

1.5. 3 Connect Intercom point in network

1.5. 4 Connect Quad switched 4 Cameras in one CM-IPC node

1.5. 5 Connect Multi Door Stations in block system

1.5. 6 Optical Fiber connection for very long distance

1.5. 7 A complex installation in residential buildings

## § 1.1 IP System Description

2-Wire systems do NOT need more cable wires to connect the components together. All the signal transfer for the system is sent via the two power wires in the power cable.

IP technology is the most common and advanced network, and the direction of system integration.

Now, 2-wire system and IP network are integrated. The IP network makes standalone 2-wire systems working together, so it can be used for complex residential blocks, even for large system.

As IP network is the backbone bus, it is ideal for simplifying installation. The system can also share the existing Ethernet(LAN) network, without a dedicated network cabling and cost.

Thanks to IP-Agent switchboard software, IP-2 wire system makes the door intercom can be available in a PC as well as from the Indoor Monitor, for answering calls and releasing doors. Additionally, video surveillance and recording can be achieved using extra CCTV cameras in network as well as entrance door station cameras.

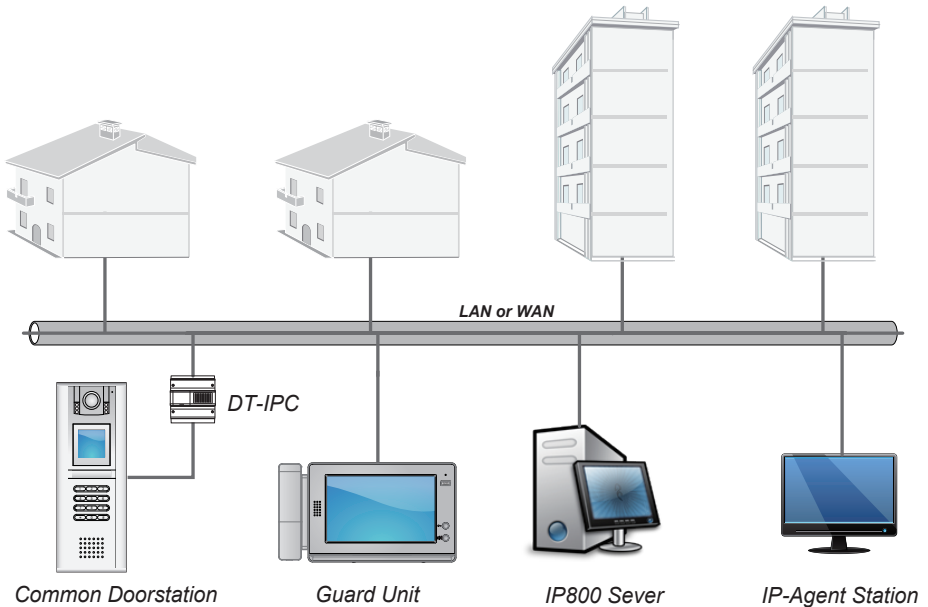

## § 1.2 IP System Part List

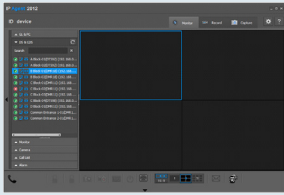

### Switchboard: IP-Agent software

#### PC software

The switchboard software may be installed on desktop or laptop pc.

- \* Windows 7 OS is recommended
- \* SQL server database is required exceptionally, if multi PC stations are installed

### HS-PC Handset kit for IP-Agent

Handset with desk mount to connect with PC.

Works with IP-Agent, to answer calls just by pick up the handset, and with 2 Unlock Buttons in panel.

- \* One USB2.0 port is required
- \* Microphone and Speaker socket will be connected



### Switchboard: IP-G21 Guard Unit

IP Guard Station with 10" TFT touch screen

- \* PS5-24V power supply is required



### Switchboard Functions:

- Answering calls from Door Station, Common Door Station, Intercom Point
- Answering calls from User Monitor
- Call Door Station, Common Door Station, Intercom Point
- Call User Monitor
- Call and communication with another online PC station or Guard station
- Entrance and Network cameras surveillance
- Door release function if called by Door Station or Common Door Station
- Call event list (Out, In, Missed calls)
- Transfer to another PC station or Guard station, if multi switchboards are installed

### IP-Agent Software:

- Video manual/auto recording and image capture, playback in multi windows

### IP-G21 Guard Station:

- Image capture and playback (800 images can be saved in flash memory)
- If 4~32GB SD card can be installed (More than 40000 images can be recorded)



### IP Gateway Converter: DT-IPC

IP Gateway Converter for 2-wire system

\* Set DIP switches correctly according to DS/CDS usage



### IP Gateway Converter: CM-IPC

IP Gateway Converter for CCTV camera

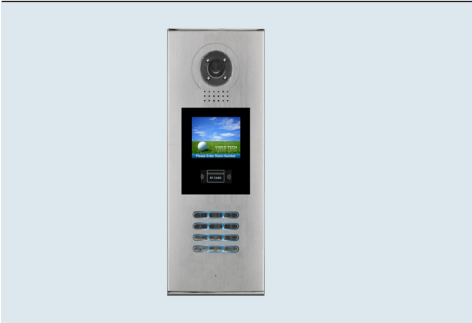

### DMR18

Digital keypad Door Panel

\* Note: Set ID Code to 0~3 for DS mode  
\* Note: Set ID Code to 4 to CDS mode



### DMR11 and EP11 Series

Direct-select Door Panel

\* Note: Can be used as Common Door Station directly

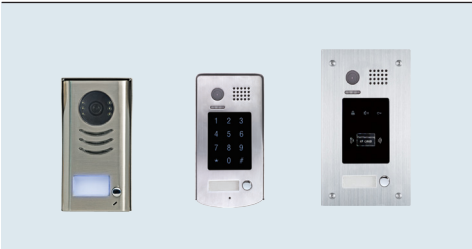

### DT-59X

1/2 Call Button Small Door Station

\* Work in Villa block, or Intercom Point in system

\* Note: For other components in system, please refer to 2-wire product information

## § 1.3 IP System Features

- 1 Entrance Door Station
- 2 User Monitor
- 3 Video Distributor
- 4 IP interface unit (DT-IPC)
- 5 Common Door Station
- 6 Switchboard using IP-G21
- 7 Switchboard using PC
- 8 Network Switcher

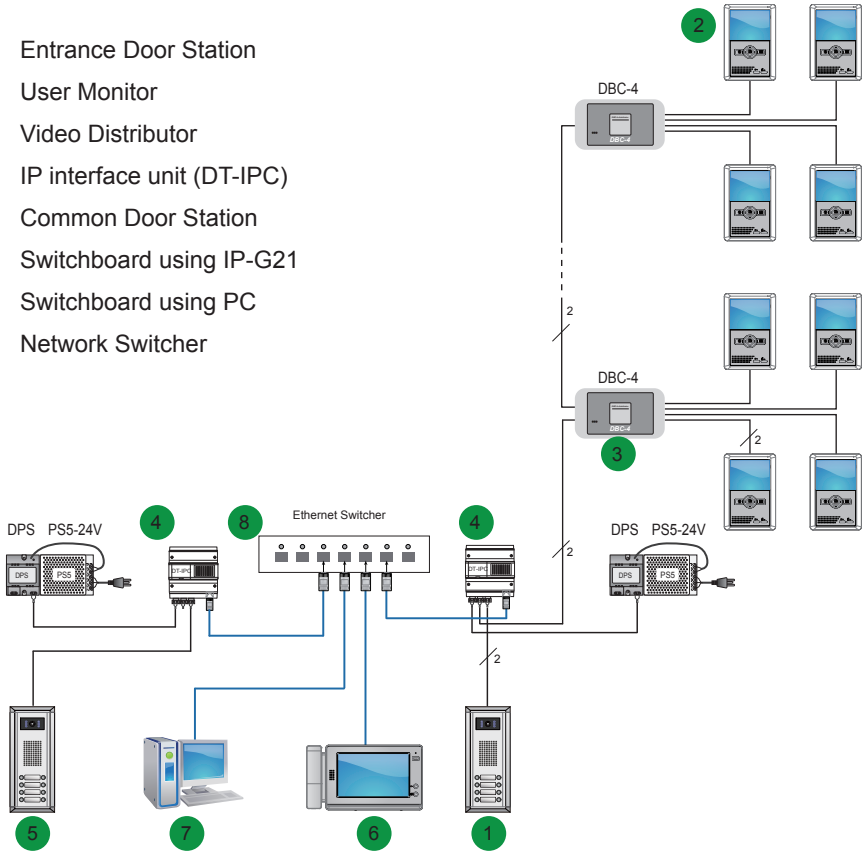

### System Capacity

IP network:	2-wire system:
1) Max. 6 PC Station (IP-Agent switchboard)	1) Max. 32 Monitors in each block
2) Max. 8 IP-G21 Guard Station	2) Max. 4 Door Stations in each block
3) Max. 200 2-wire system blocks	3) Max. 300m distance
4) Max. 200 Intercom Point	4) Max. 6 CCTV cameras
5) Max. 32 Common Door Station	
6) Max. 32 IP network camera controller	
7) Max. >10Km distance (By using optical fiber)	
*Note: For 3/4/5/6 items, total number < 240	* Note: Refer to DT technical Guide

## § 1.4 IP System Typical Applications

### 1.4.1 Connect with PC in single family system

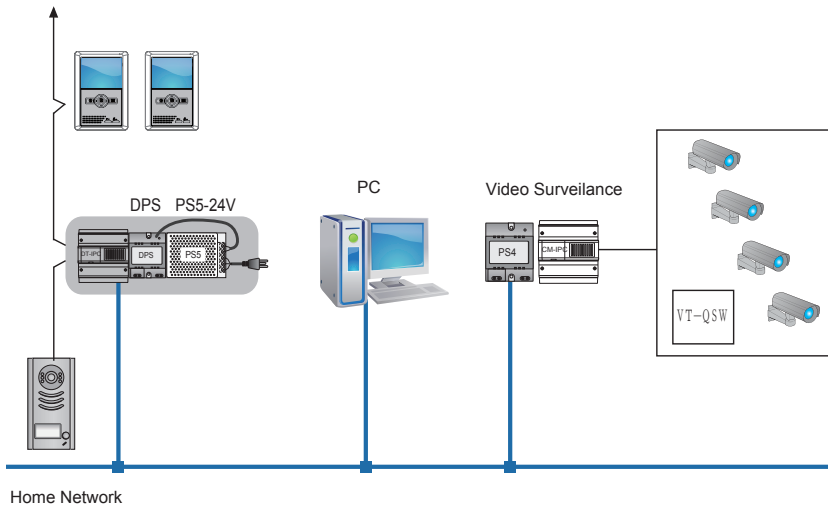

1. Answer calls and release the door from PC
2. Monitoring Door Station camera or Video Surveillance cameras from PC

### 1.4.2 Connect Common Door Station in system

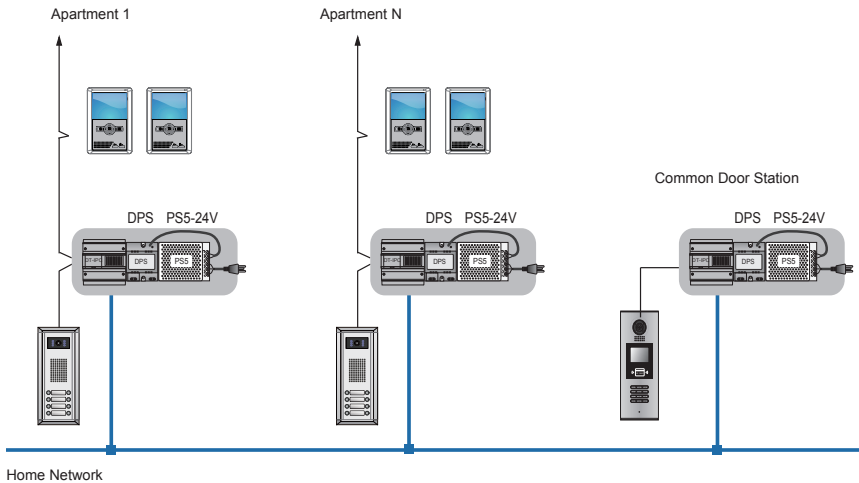

1. All Common Door Stations can call all the unit in each apartment
2. Switchboard is not needed in this case

### 1.4.3 IP system Diagram for complex residential buildings

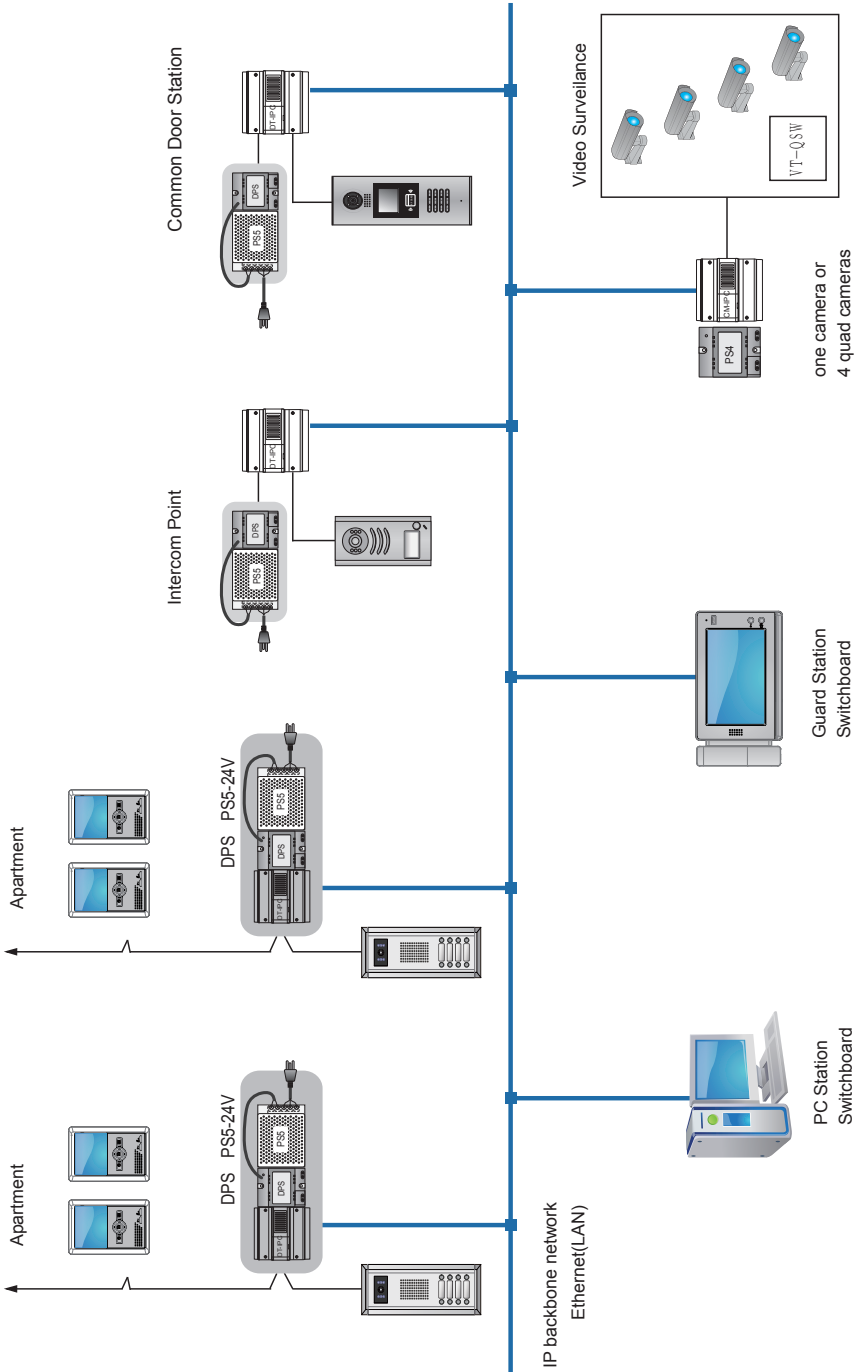



## § 1.5 Wiring Diagram

### 1.5.1 Connect with PC in single family system

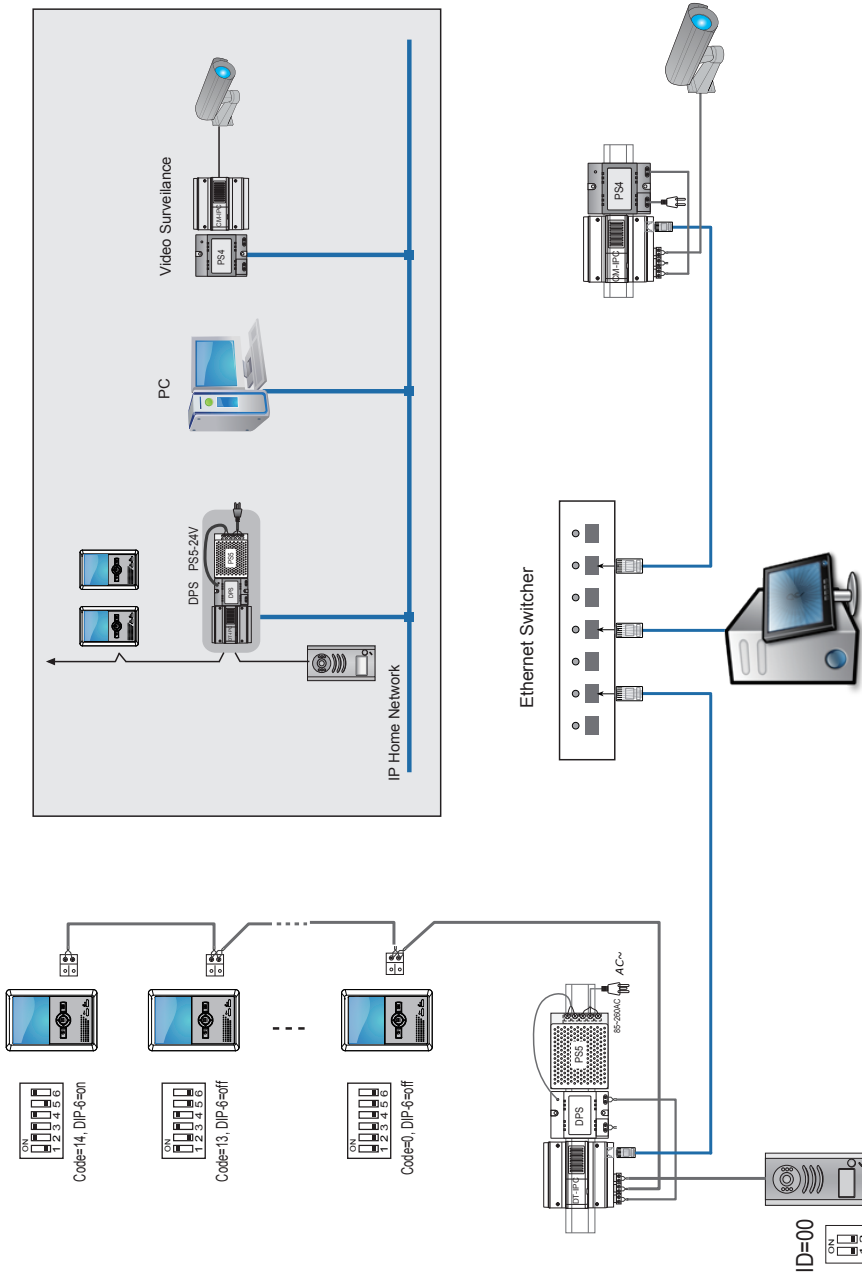

## 1.5.2 Connect Common Door Station in Apartment compound

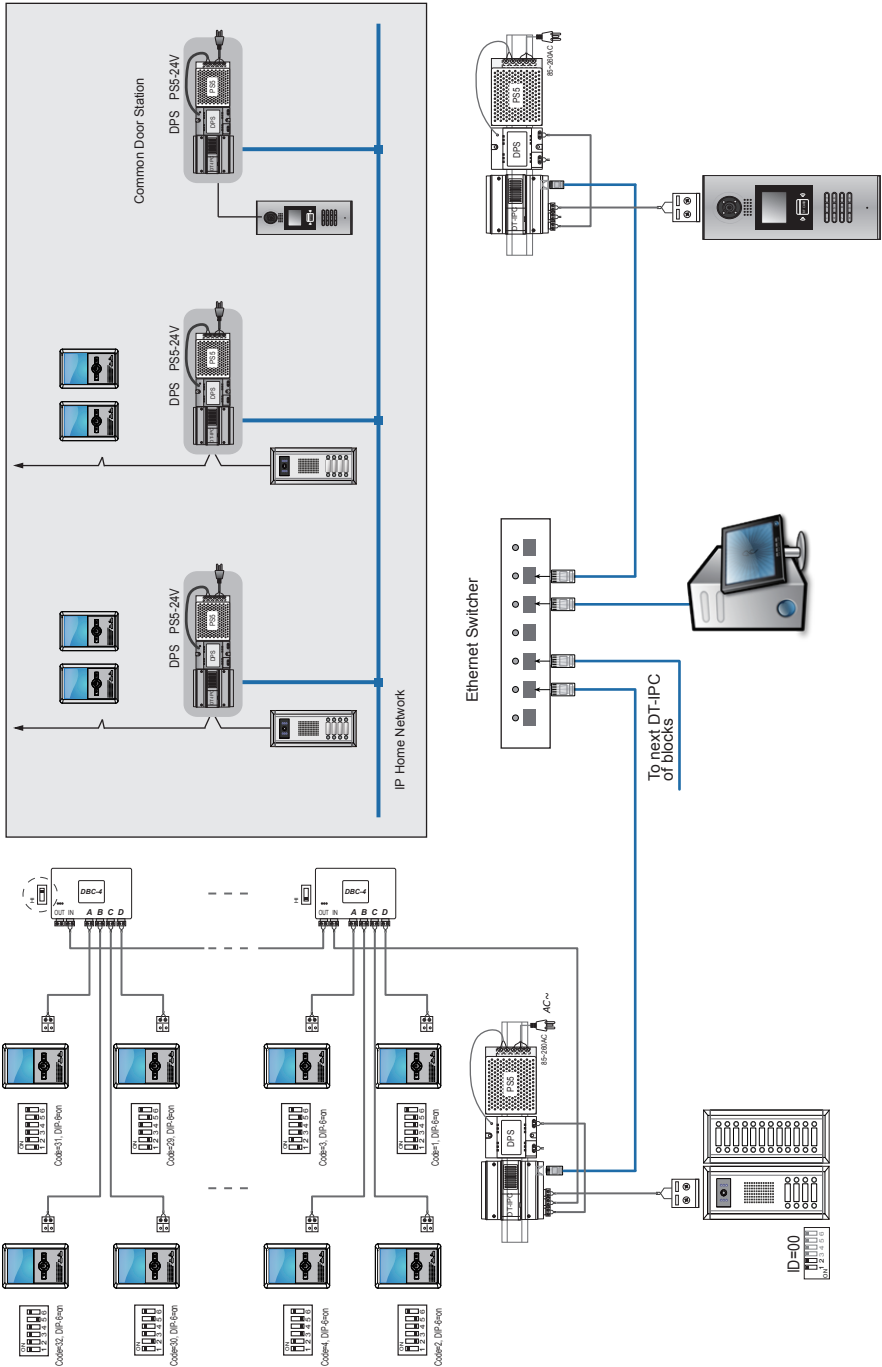

### 1.5.3 Connect Intercom point in network

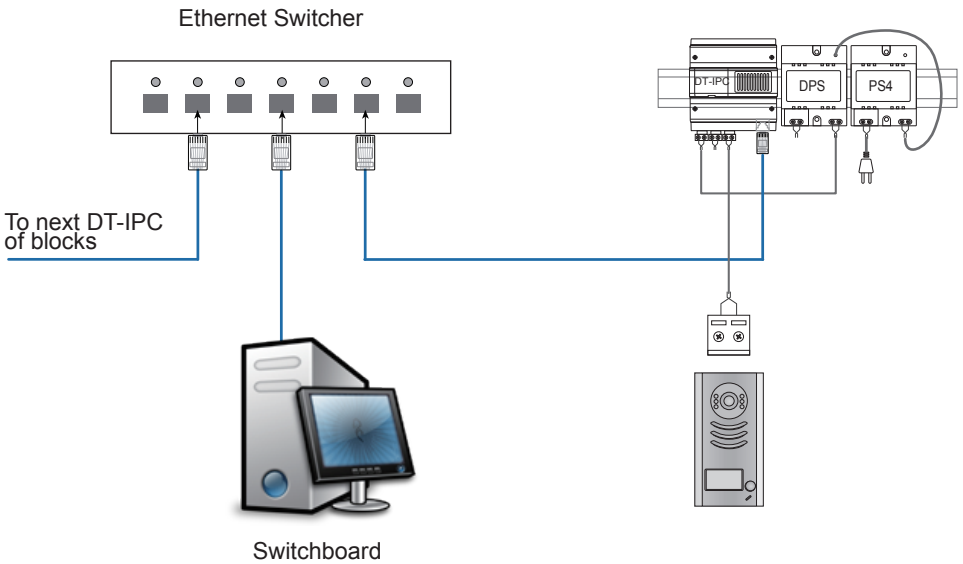
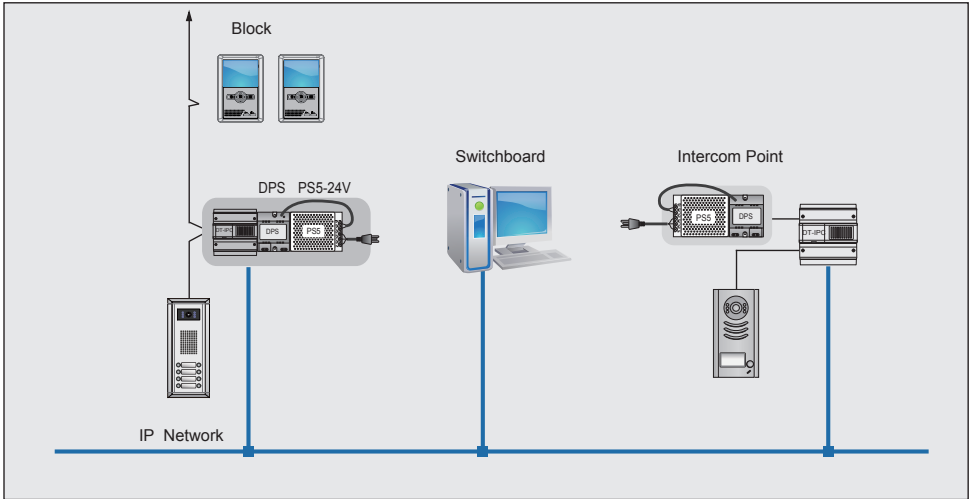

### 1.5.4 Connect Quad switched 4 Cameras in one CM-IPC node

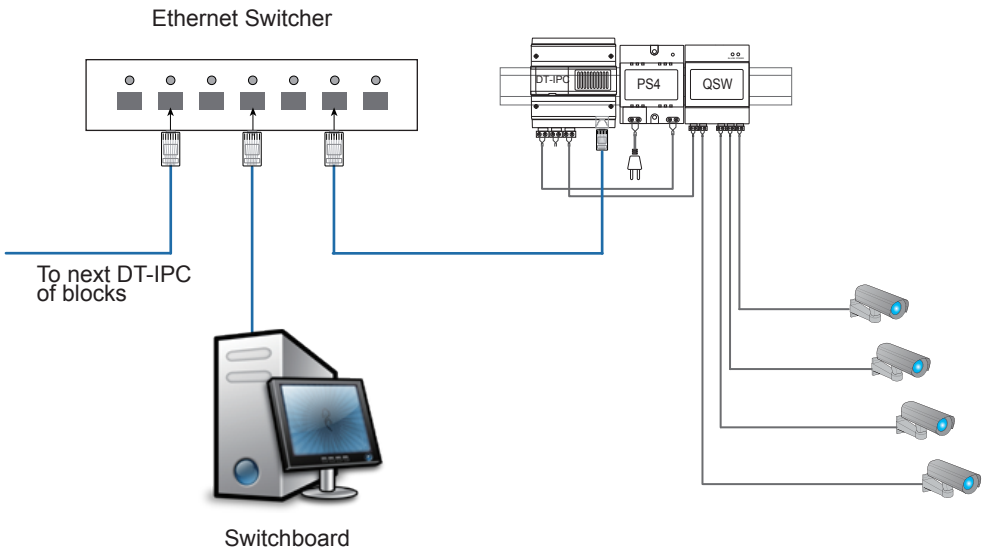
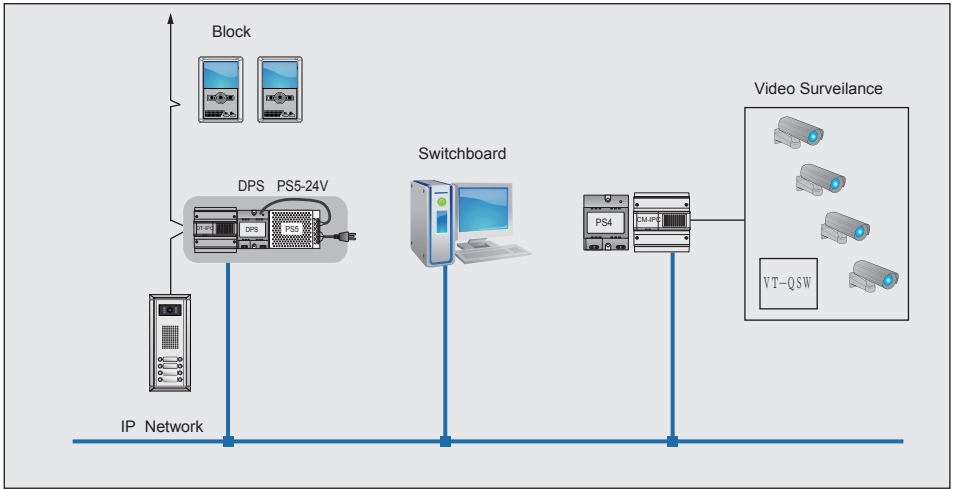

### 1.5.5 Connect Multi Door Stations in block system

- DBC4S is used for Door Station distributor (Setup the current according to different models)
- Refer DT system technical Guide for reference

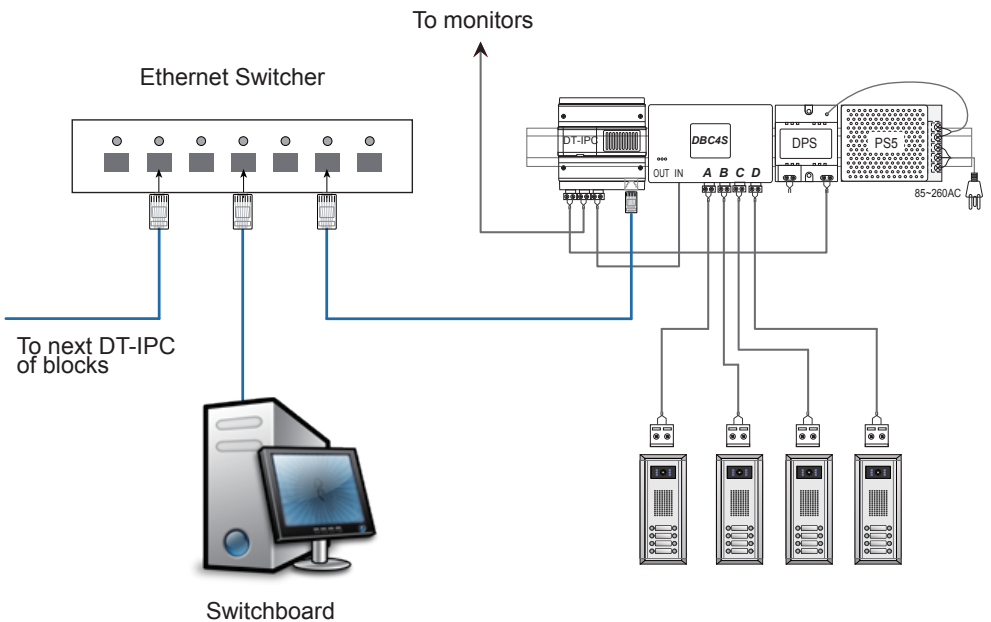
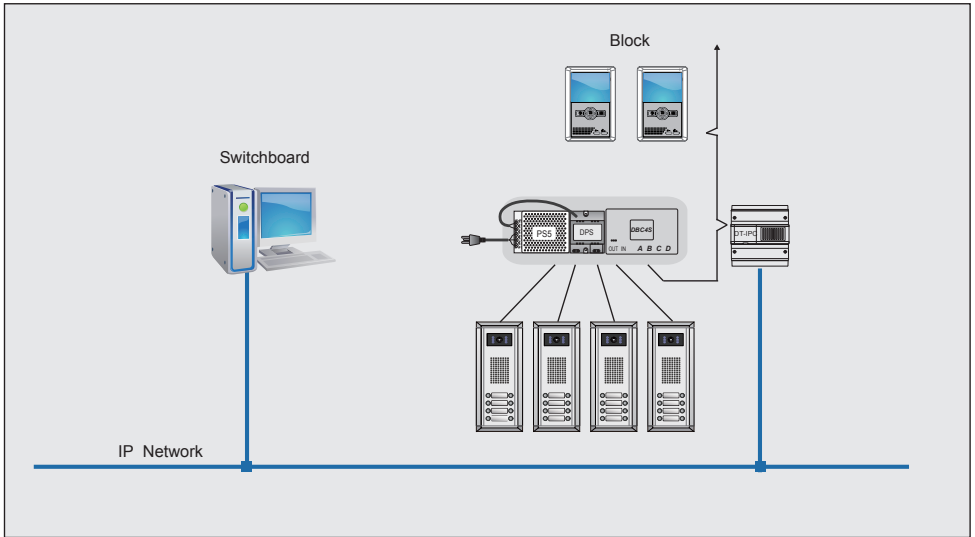



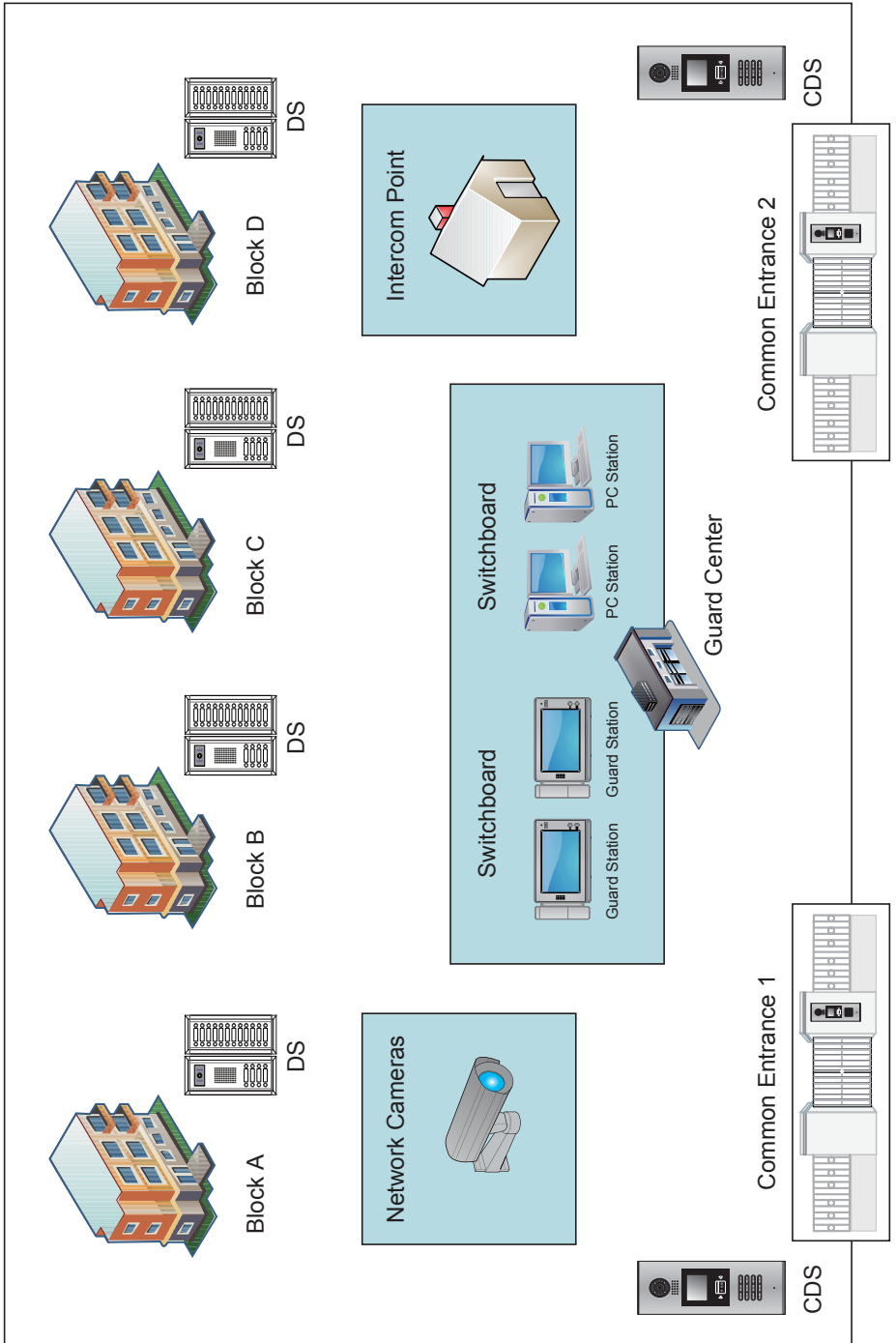

### 1.5.7 Optical Fiber connection for very long distance

- LAN network using fiber optic, brings insulation among the systems; this ensures a higher degree of immunity from lightning damages.
- Using IP as repeater can meet a large distance between the Door Station and Monitor.

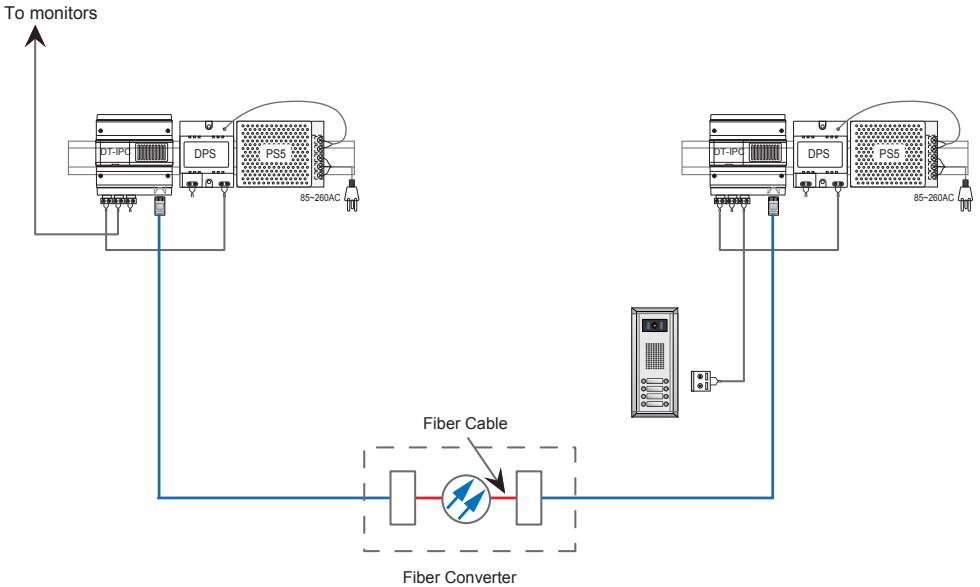
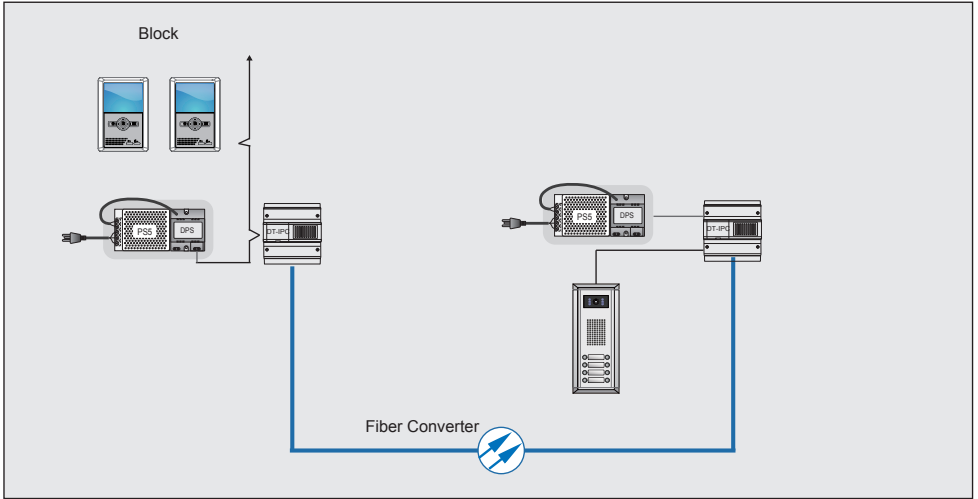



# Chapter 2

## Product Introduction

### 2.1. IP-G21 Description

#### 2.1.1 About IP-G21 Unit

#### 2.1.2 Parts and Functions

#### 2.1.3 About main menu

#### 2.1.4 Specification

### 2.2. DT-IPC Introduction

#### 2.2.1 About DT-IPC Unit

#### 2.2.2 Parts and Functions

#### 2.2.3 Specification

#### 2.2.4 Installation Setup Instructions

#### 2.2.5 Wiring Diagram

#### 2.2.6 IP Address Setup

## § 2.1 IP-G21 Description

### 2.1.1 About IP-G21 Unit

The IP-G21 Guard Unit is designed as a dedicated switchboard to support IP network system, which can be used for 2-wire or CAT5 network system.

Guard Unit is an essential part in IP system, it makes possible to manage calls from(to) Common Door Station or Door Station, and Indoor Monitor.

Additionally, IP-G21 has other functions, such as alarm receiver, depends on system configuration.

Max. 8 IP-G21 can be connected in system.

- 10 inch digital TFT with its resolution of 800x480 pixels
- Touch screen operation
- Handset or hands free answering
- Make intercom call to common door station,door station,and indoor monitor

### 2.1.2 Parts and Functions



### 2.1.3 About main menu

The main menu is your starting point for using all the applications on G21.

To open the main menu page, press the LCD screen anywhere twice. Please see the above diagram. total 7 items shown on main menu page: Manual Monitor, Intercom, Event, User Setup, Shortcut, Service, Close.

## a. Manual Monitor:

Press **Manual Monitor** icon on main menu page, a digital keypad will be shown on screen. Input the address by pressing the keypad, then press **unlock** or **monitor** icon, you can release the door or see the conditions of common door station or door station.



Otherwise, you can monitor or release the door for common door station or door station by name list, please press **List** icon to show the name list.



## b. Intercom:

The Guard Station can make a call to common door station, door station and indoor monitor, just input the address by pressing keypad, then press **Dial** icon to activate the intercom call. (the intercom call also can be activated by namelist, just press **List** icon to show name list )



## c. Event:

Press **Event** icon on main menu page ,total 8 items on this page.

It's available for G21 to search alarm and calling information, and can directly clear all events on G21. just press **Event Clear** icon.



The G21 supports picture memory function, and the pictures can be played back on G21, at this page, press **Memory Playback** icon, each memo can display 4 pictures named by date, and the pictures can be copied to SD card, just press **Memory to SD** icon.

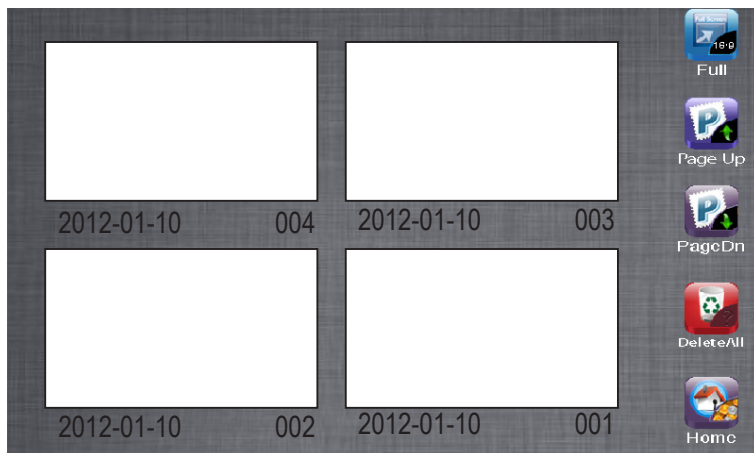

#### d. User Setup:

User setup includes date and time set, ring tone set, monitor time set, password set, call divert set, menu upgrade, and system tools set. These setting items can be modified at any time. If you want to restore the settings to their default value, please press **Restore to default** icon.



## e.Shortup:

This section offers more convenient and effective methods for guard person to make a call,just pressing the icon,calling is activated immediately.



## f.Service:

### 2.1.4 Specification

Power input:	DC 24Vdc (supplied by DT-DPS)
Standby Current:	190 mA
Working Current:	250mA
Screen:	10 inch digital TFT
Resolution:	800x480pixels
Video Signal:	CCIR, 1Vp-p , 75Ω
Transmission Mode:	TCP/IP
Connection Port:	RJ45
Network Interface:	Standard Ethernet interface
Working temperature:	+5°C ~ +40°C
Dimension:	382(W)X203(H)X32(D)mm

### 2.2.1 About DT-IPC Unit

The DT-IPC unit is designed for DT 2-wire system to support IP networking. It is a network gateway which is an essential node in IP network.

DT-IPC is capable of connecting block system and Common Door Station, intercom point. It makes the door intercom can be available in a PC as well as from the Indoor station or Guard Unit. Answering calls and releasing doors, or monitoring entrances are also available.

Max. 239 DT-IPC can be connected in system.

- One DT-IPC is required in one block.
- Built-in watchdog circuit in case of crash.
- LED Indicators to show system status
- RJ45 Standard connection port
- IP address setting & store
- Talking volume adjustable
- Support TCP/IP network and fiber transmission or broad band network access.
- Adopt MPEG4 video protocol and G.729 audio protocol.
- Include 100Mbit Ethernet LAN and RS485 connection port.

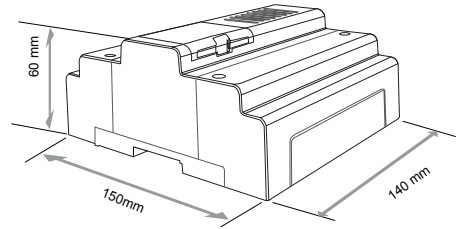

### 2.2.2 Parts and Functions

Diagram:

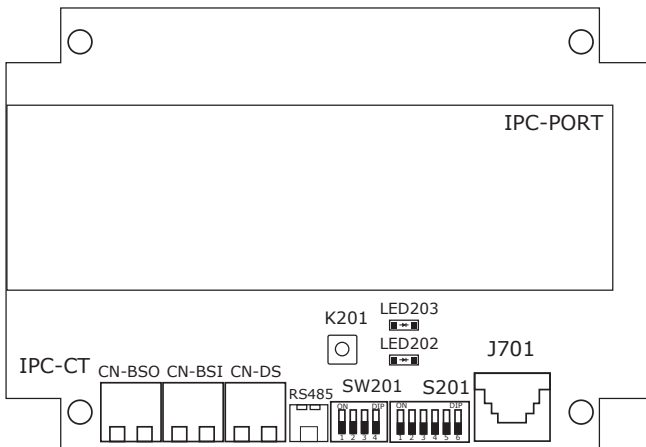

## Terminal description:

Item	Name	Description
Status indicator	LED202	After power on for 10s,it will flicker Always on while working
	LED203	
DIP switches	SW201	Refer to DIP switches setting in followings
	S201	Refer to DIP switches setting in followings
Network Signal Input	J701	RJ45 connection, connected to network.
Bus Signal Output	CN-BSO	2 wire terminal connection,to DT-DPS connection
Bus signal input	CN-BS1	2 wire terminal connection, to monitors or DBC4s that monitors are connected
Bus signal input	CN-DS	Connected to door station or DBC4s that door stations are connected
Prog Button	K201	Reserved
PC port	RS485	Set parameters of DT-IPC by PC that is connected by RS485-USB Converter

### 2.2.3 Specification

Power input:	DC 24Vdc (supplied by DT-DPS)
Standby Current:	190 mA
Working Current:	250mA
Video Signal:	CCIR, 1Vp-p , 75Ω
Audio Signal:	300~3,400 KHz, 0~240 mV
Transmission Mode:	TCP/IP
Connection Port:	RJ45
Network Interface:	Standard Ethernet interface
Working temperature:	+5°C ~ +40°C
Dimension:	140(W)X60(H)X150(D)mm



## 2.2.4 Installation Setup Instructions

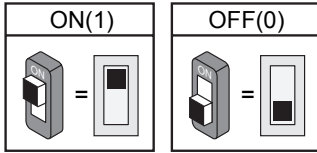

a) DIP switches settings:



DIP Switch Status(Defaults are OFF)







S201 switches settings:

Total 6 bits switches.Bit-6 is used to set the video impedance matches.

Bit state	Setting	Bit state	Setting
	Set to high impedance		Match video impedance

Functions of bit1 to bit 5 are reserved.

SW201 switches settings:

Item	Bit state	Descriptions
Bit-1	//	Reserved
Bit-2		Villa application mode
		Apartment application mode
Bit-3		Set to "on",press Direct Call Guard Unit on monitor to call switchboard
		Set to "off",press Direct Call Guard Unit on monitor to call local Guard monitor
Bit-4		Set as common door station
		Set as door station

## 2.2.5 Wiring Diagram

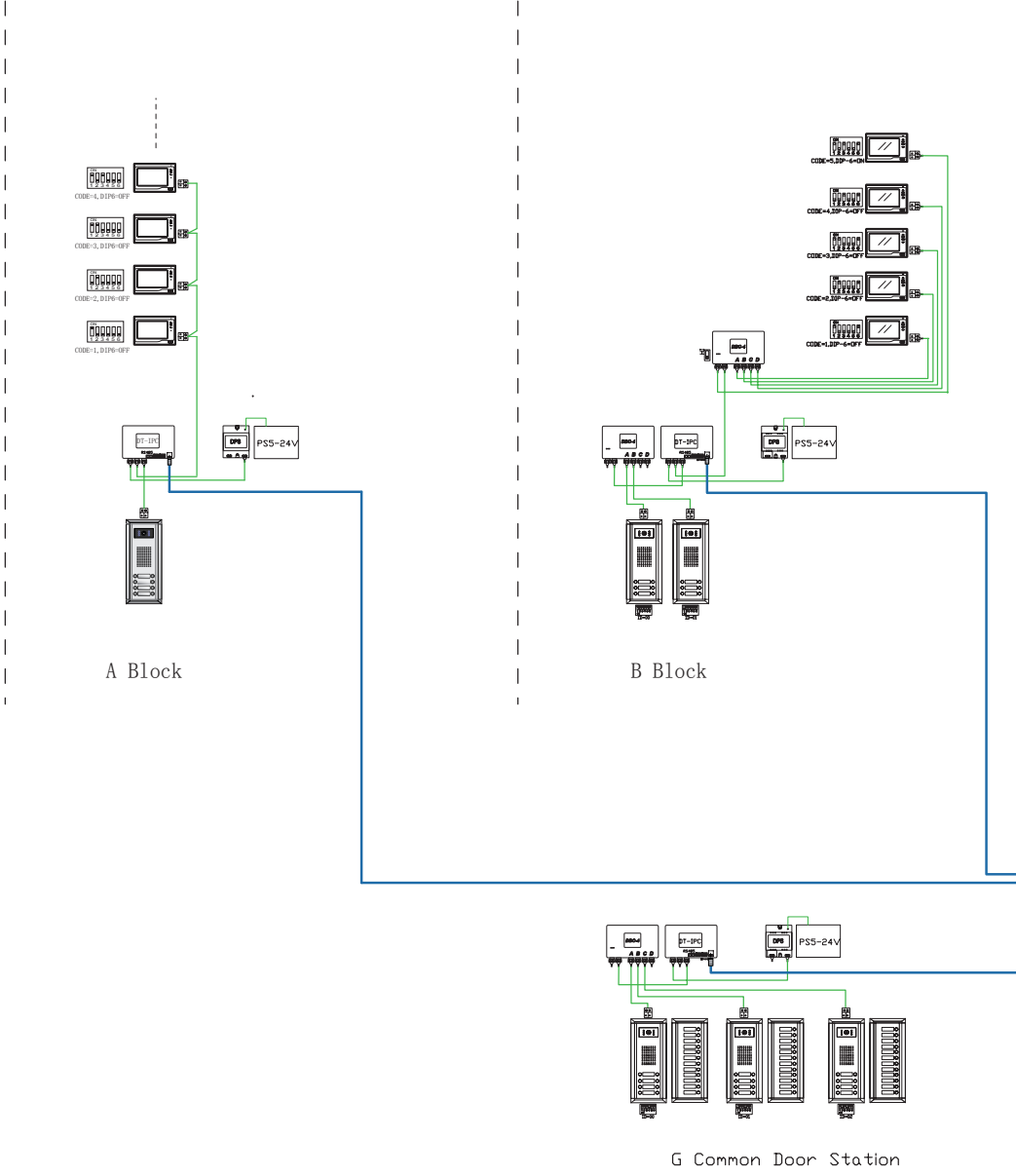

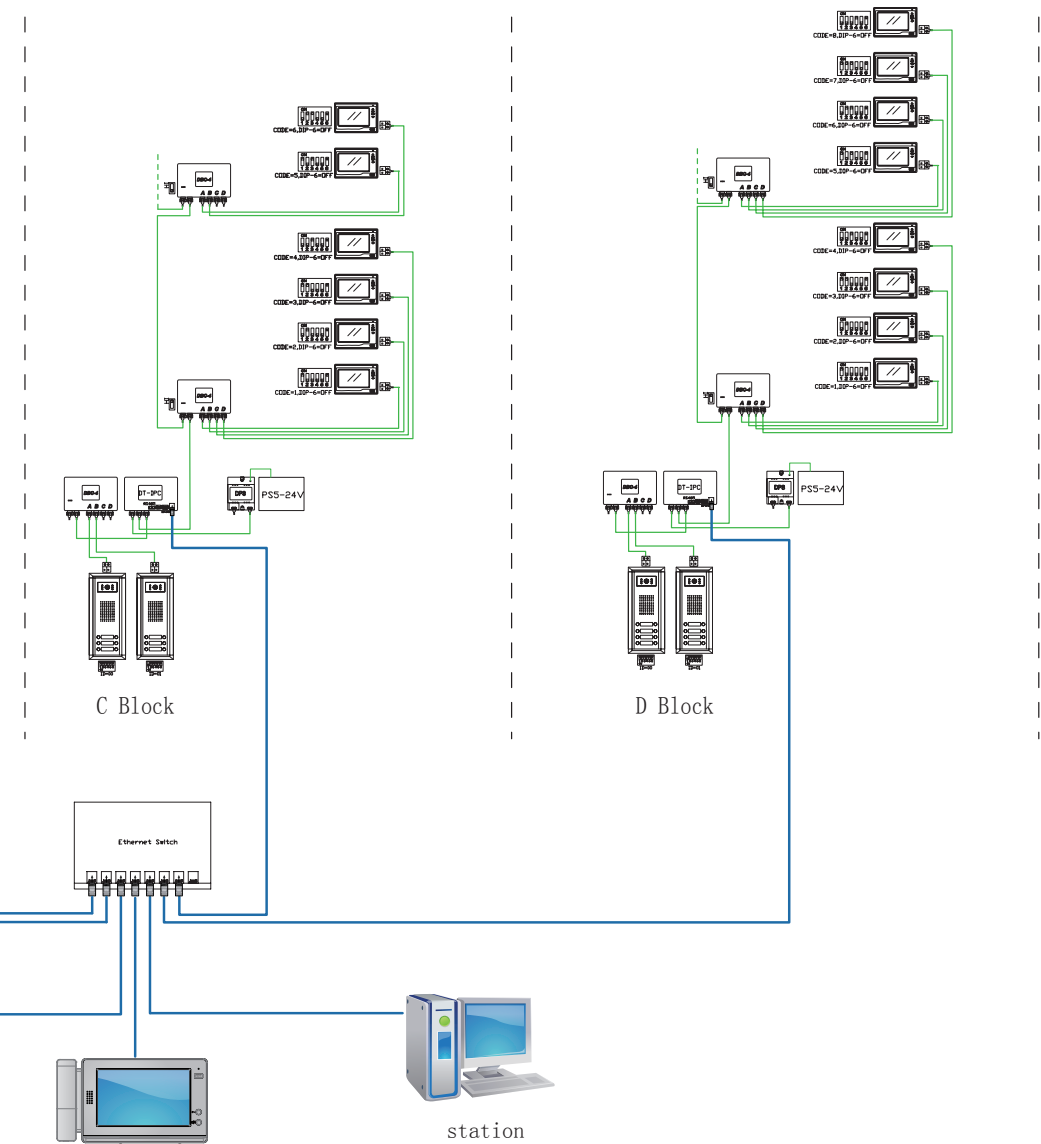

Guard Unit

station

- Twisted Pair Cable (2x1.0mm²)
- CAT5

## 2.2.6 IP Address Setup

For constructing a DEDICATED LAN for IP system, all network devices must be specified different IP Address.

- \* Network device model includes DT-IPC, CM-IPC, IP-G21 and PC Station. We will just state device short for network device in the following statement.
- \* All network device can be detected by IP8210 config and IP-Device, but only DT-IPC, CM-IPC & IP-G21 can be set by the two softwares. PC Station is set by Windows IP setup

### 1. General Rules for IP Address Setup

All the devices must be in the same IP Segment. (Assume that using the segment: 192.168.0.X in this manual )

- \* 192.168.0.1 is used as a network gateway. Devices can't be set to this address
- \* All devices must be set a unique IP address & MAC address
- \* If more than one device have the same IP address, only one of them can be available by IP8210 config or IP-Device software
- \* If PC & the device to be set have the same IP, the device can't be detected by IP8210 config or IP-Device software in this PC.
- \* Here are the table for range of device IP address

Range:	Device:
192.168.0. 2 – 192.168.0. 240	DT-IPC, CM-IPC
192.168.0.241– 192.168.0.246	PC Station(IP-Agent)
192.168.0.247 – 192.168.0.254	Guard Station(IP-G21)

### 2. IP Address Setup by IP8210 Config Software

For new devices, IP address of devices are initialized to the same address, so it's recommended that IP address of devices is set one by one. It's easily fulfilled via IP8210 Config software.

## Steps for IP Setup

a. Set PC IP address (Assume that IP of PC is set to 192.168.0.125)

\* See the notification area in the bottom right corner of windows desktop



\* Press  icon in the notification area. It will pop up a window for selecting network.

Click Open **Network and Sharing Center** item.



\* Select Local Network in the pop-up window.

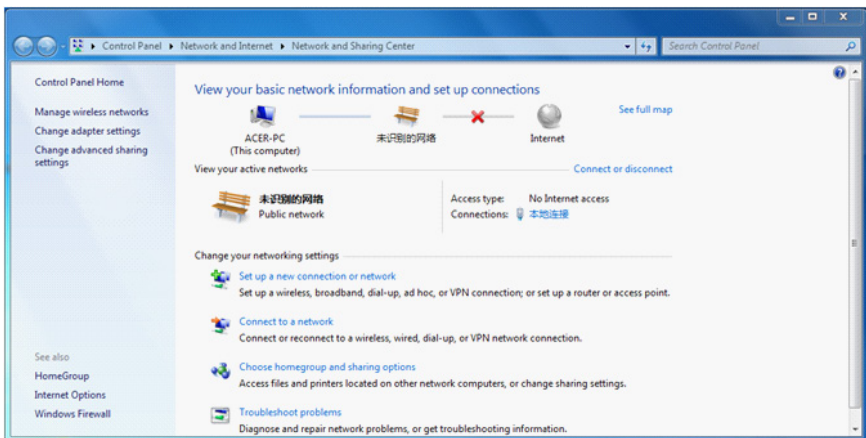

\* Press Properties button in the Local Network Status window

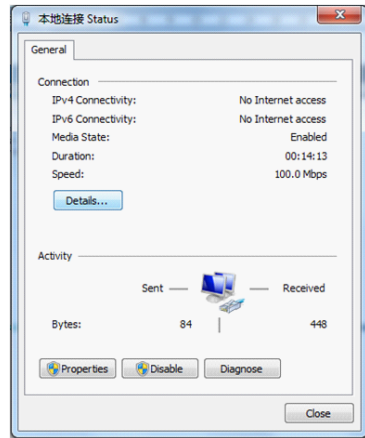

\* Select Internet Protocol Version 4(TCP/IPv4) item in the Networking tab of Local Network Properties window

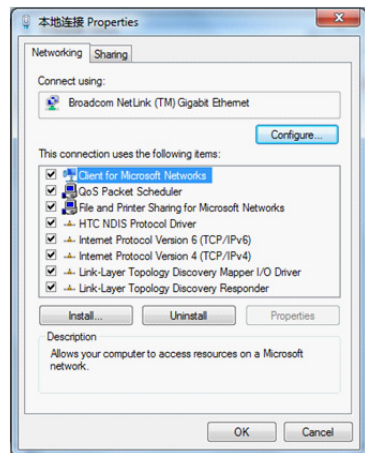

\* Select Use the following IP address option in the General tab of Inter Protocol Version 4(TCP/IPv4) Properties window

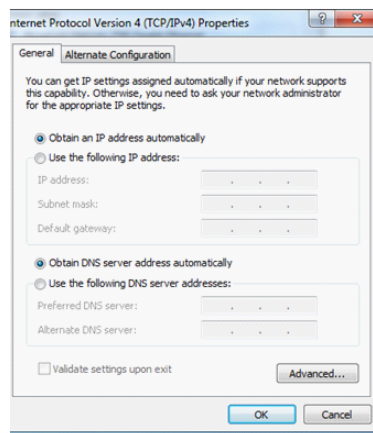

\* Input IP address, Subnet mask and Default gateway as following picture shows, then press OK button to finish setup

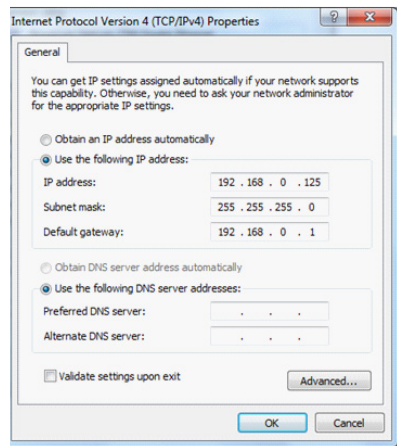

b. Connect device to PC directly or the network

c. Start **IP-8210 Config** Software

\* The path to get the software: \K 2012\Tool\IP8210Config\

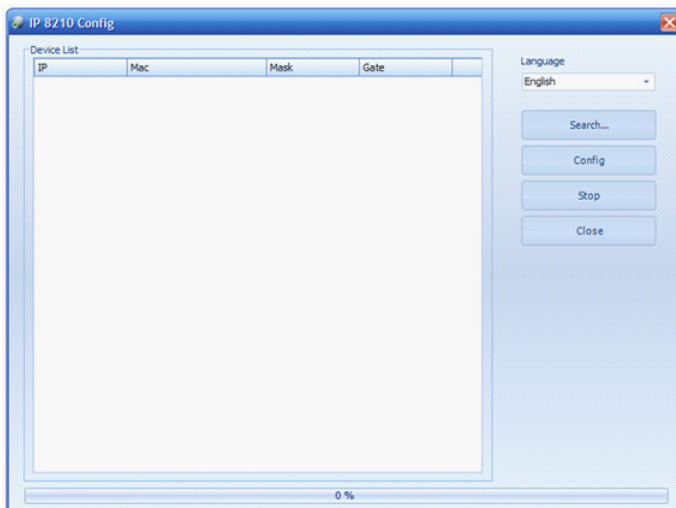

d. Press Search... button to search the device. You can press Stop button to end the search after the device has been detected. Just like the following picture shows

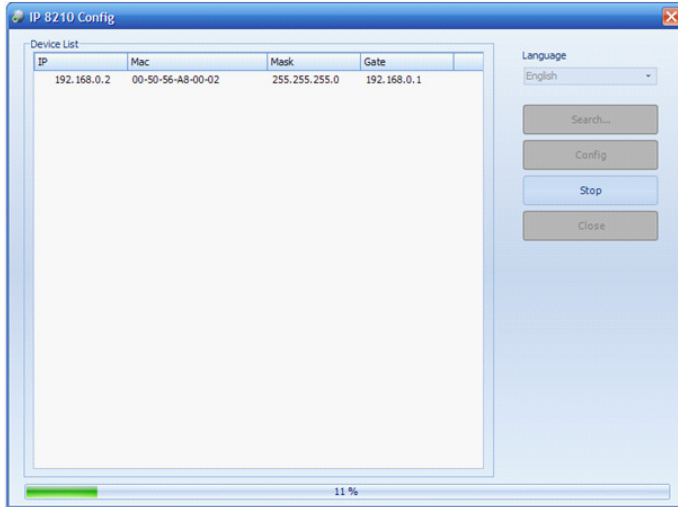

e. Select the device in the Device List frame, then press Config button

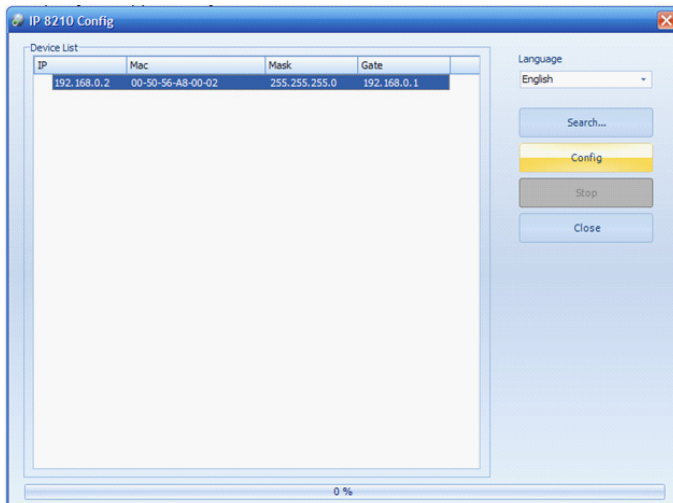



f. It will pop up a window for IP address config. Modify IP address, and then press OK button to confirm. Its Mac address will be automatically modified simultaneously.

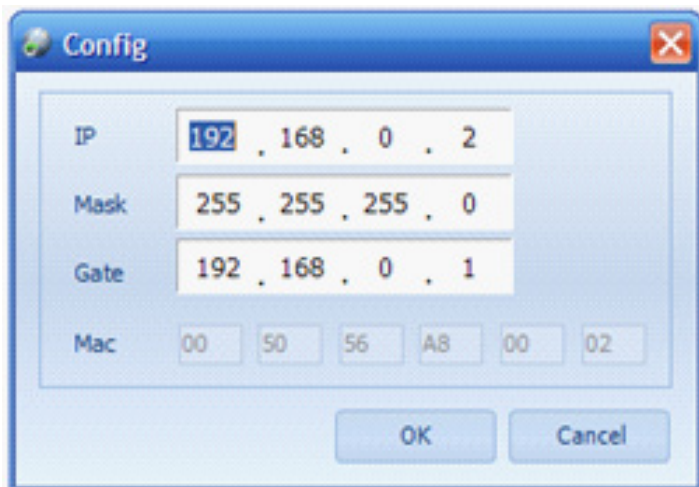

g. If setup is successful, it will pop up a window to inform you. Press 'Confirm' button

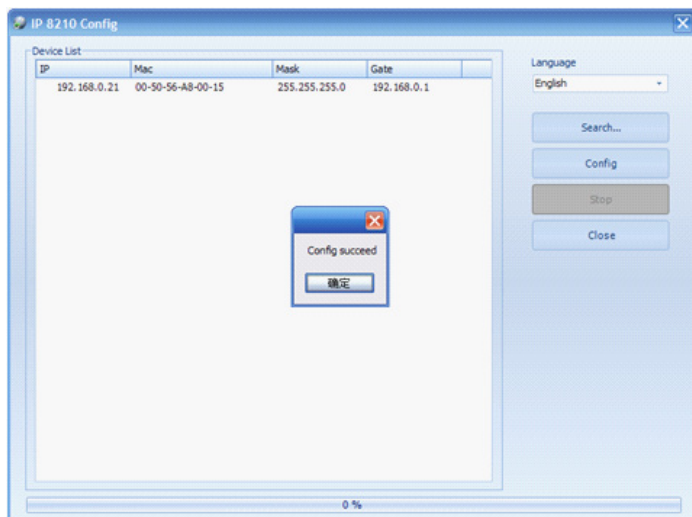

### 3. IP Address Setup by IP Device Software

An IP setup tool has been inserted in IP Device software. The function is the same to IP8210 config software.

#### Steps for IP Setup

a) Install PC Station package software. And IP Device software shortcut will be created automatically in the desktop.

b) Set PC Station IP

Assume using the following IP address :

IP address: 192.168.0.246

Subnet mask: 255.255.255.0

Default gateway: 192.168.0.1

Note that IP address range of PC station must be from 192.168.X.241 to 192.168.X.246. X is the specific segment number that is configured by IP Device. Assume that 0 segment has been specified.

c) Connect the device to PC directly or the network

The following is a diagram of network connection

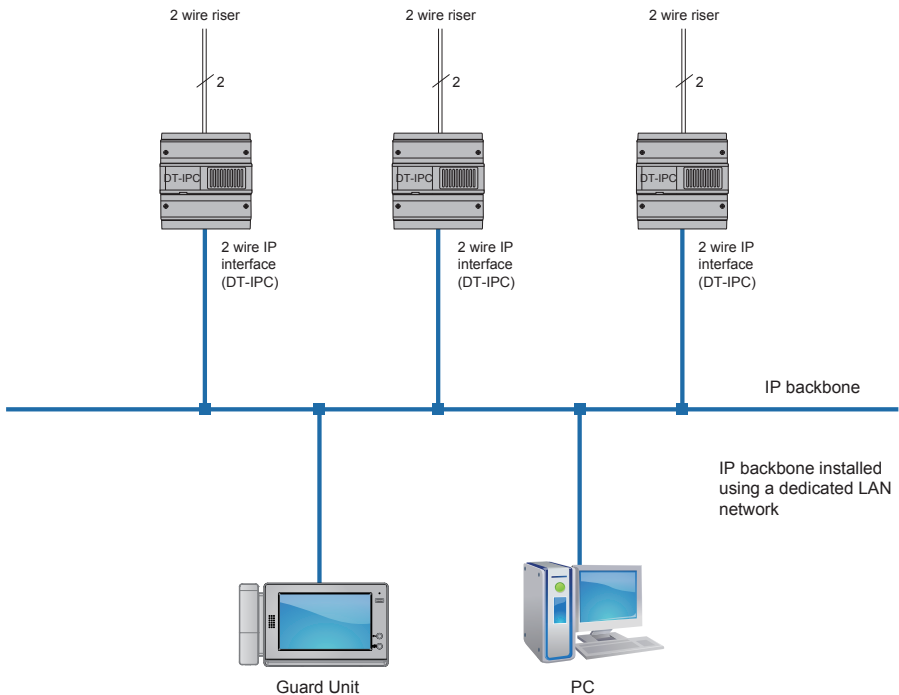

d) Start **IP Device** software

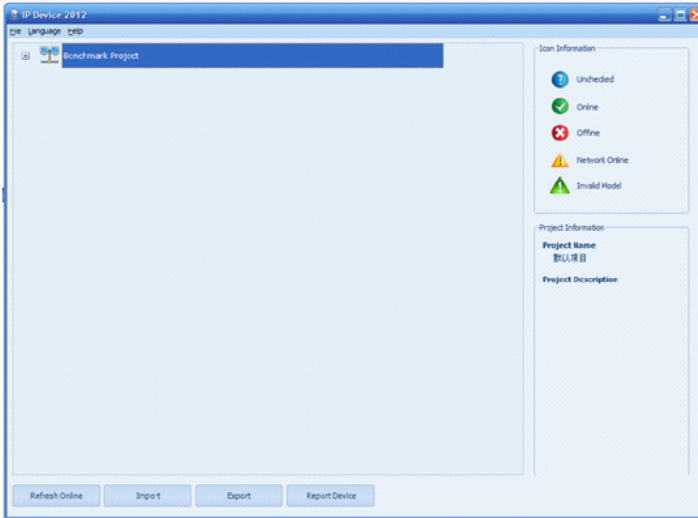

e) Click right mouse button on **Benchmark Project**, then select **IP Node Config** in the pop-up menu

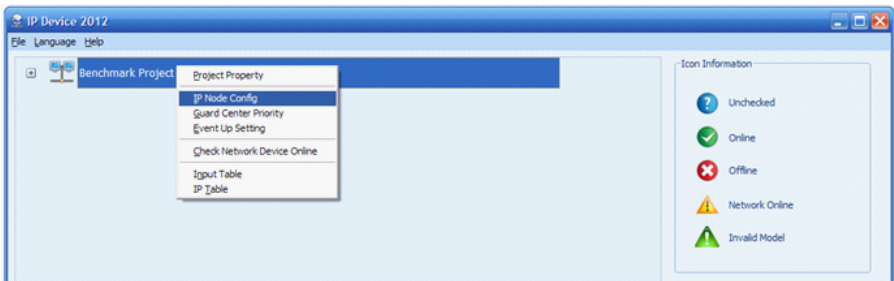

f) In IP Node Config page, press **Scan & Check** button

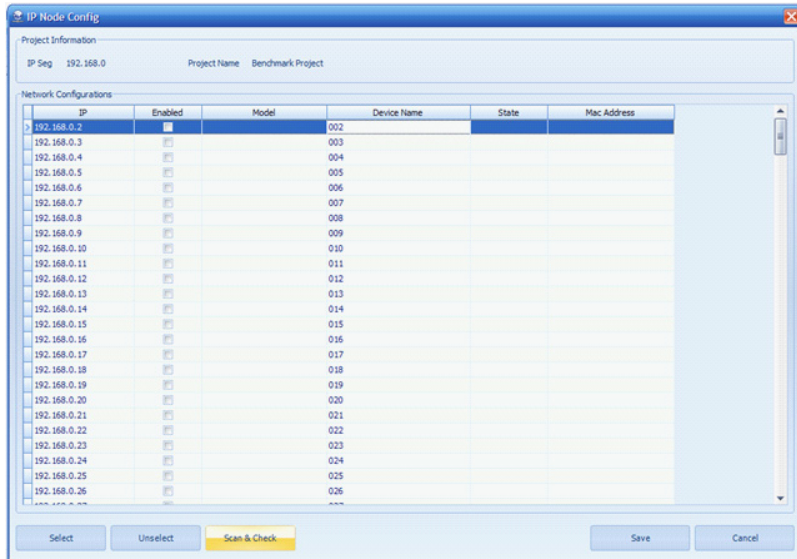

g) Then it will pop up a window to show devices that are detected. Assume that 192.168.0.2 is the device that is supposed to be set to 192.168.0.93.

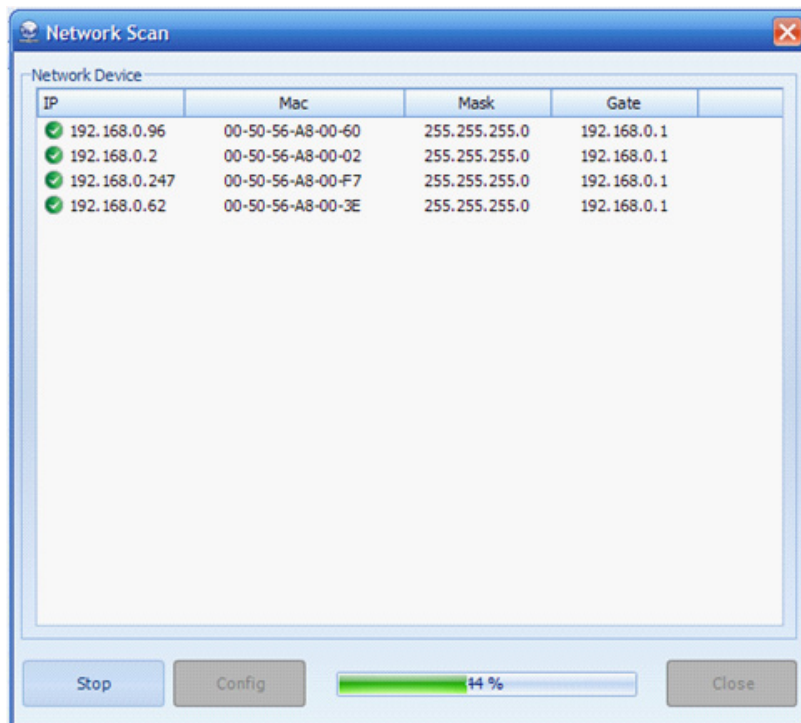

h) Double click 192.168.0.2, then a window pops up for modifying IP, input 93 then Mac address will be automatically modified. Press OK button to confirm modification.

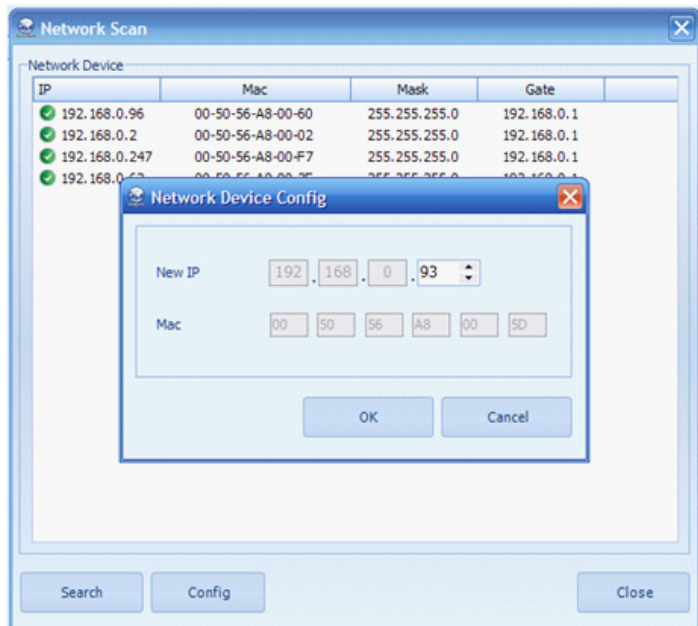

i) A window will be pop up to inform you if config succeed, just like the following picture shows. Press 'confirm' button

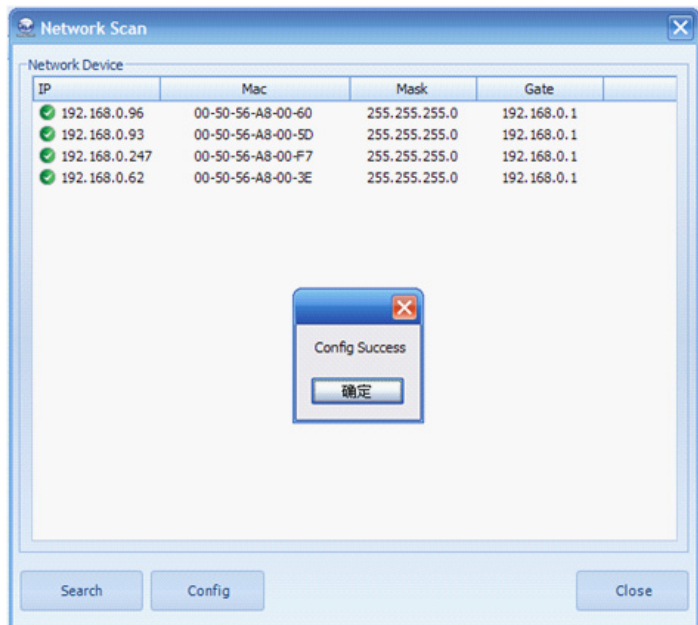

#### 4. Find Specific Network Device in IP System

In the IP system, if you want to check device IP or find specific network device, you can operate it as follows, take DT-IPC as example.

##### a. Check Device IP

1) Press K201 button in DT-IPC

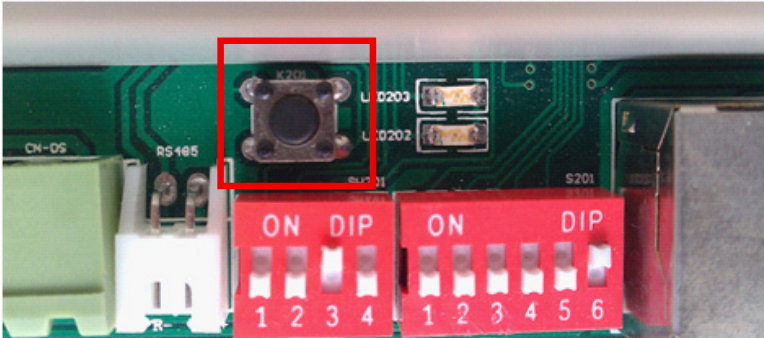

2) Device info will be shown in IP device software in 2s. The device info format is as following picture: 'Device Test Tip: + Device name + Device IP

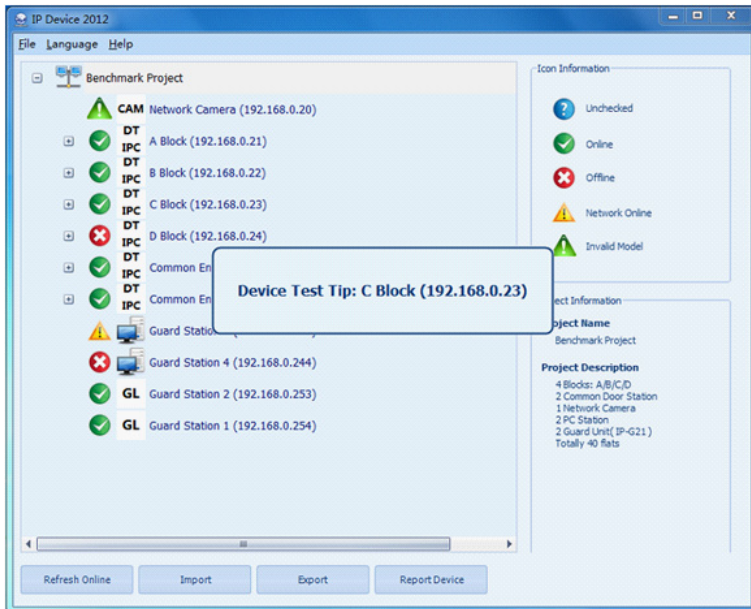

## b. Find Specific Network Device

If you don't know the related device of specific IP address, you can find out the relationship by tip device function in IP device software.

1) Select one IP device you want to check, click right mouse button on it, select Tip Device in the pop-up menu.

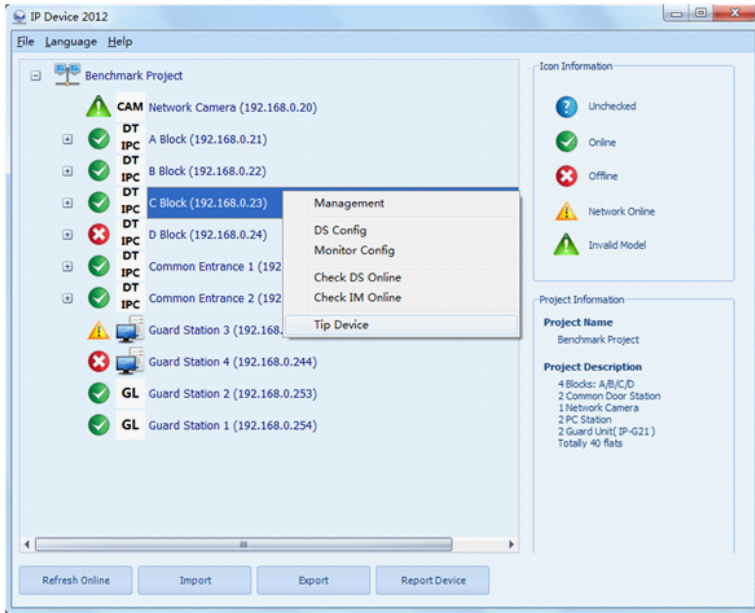

2) Then LED202(red)&LED203(blue) of the related DT-IPC will blink 8 times simultaneously.

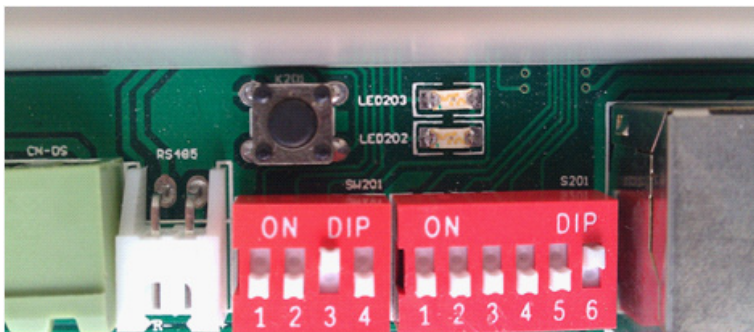

## 5. Check Network Device Online

The status of devices is unchecked after configured. The following are two methods for checking network device online

- 1) Press Refresh Online button on the left-bottom corner in main page of IP device software.
- 2) Click right mouse button on Benchmark Project, then select Check Network Device Online in the pop-up menu.

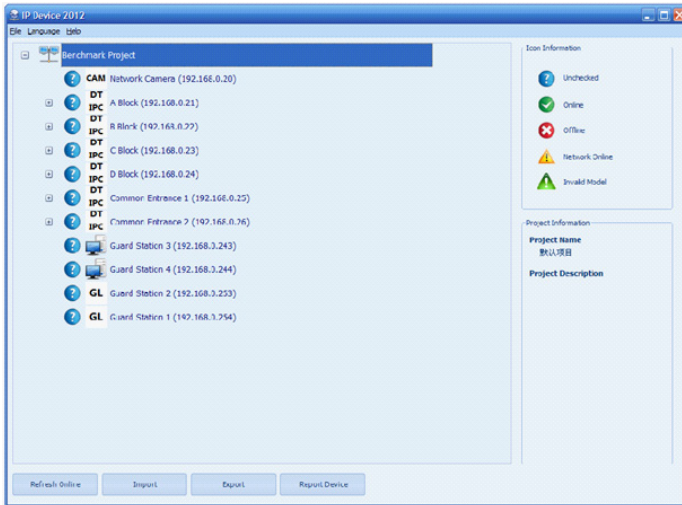

As you see, D Block, Guard Station 2 & Guard Station 1 are offline. Network Camera is online, but device model doesn't correspond with the connected device. Other devices is normally online.





# Chapter 3

## Software Introduction

3.1. Software Installation

3.2. IP-Device Introduction

3.3. IP-Agent Introduction

3.3. 1 Overview

3.3. 2 IP-Agent Description

3.3. 3 Monitor Viewer

3.3. 4 Record Viewer

3.3. 5 Capture Viewer

3.3. 6 Setting

## § 3.1 Software Installation

1. Double Click Setup.exe. Start to install PC Station

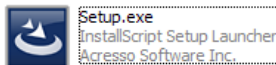

2. Select language, then click Next.

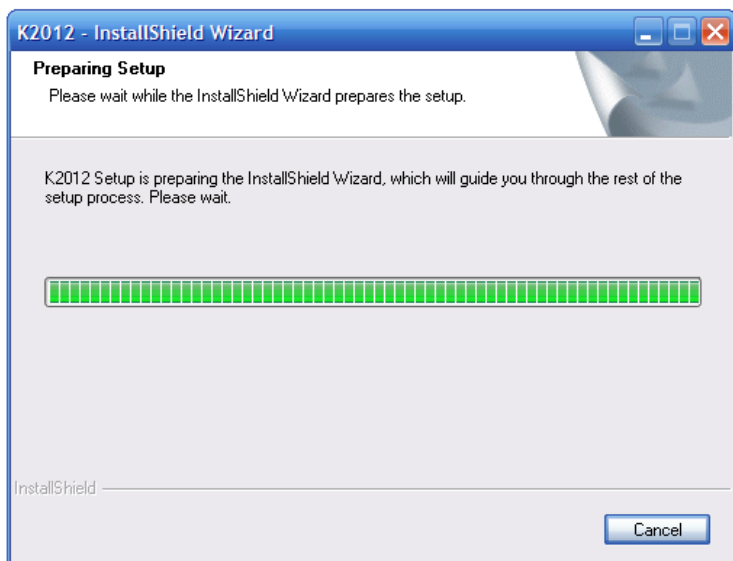
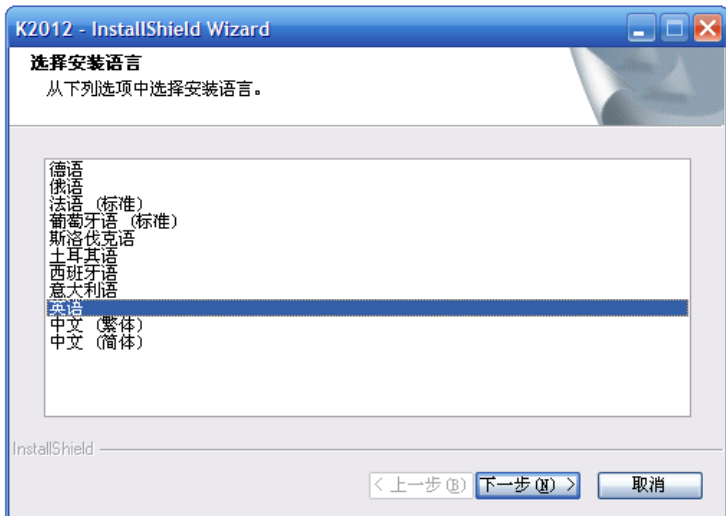

3. Click Next

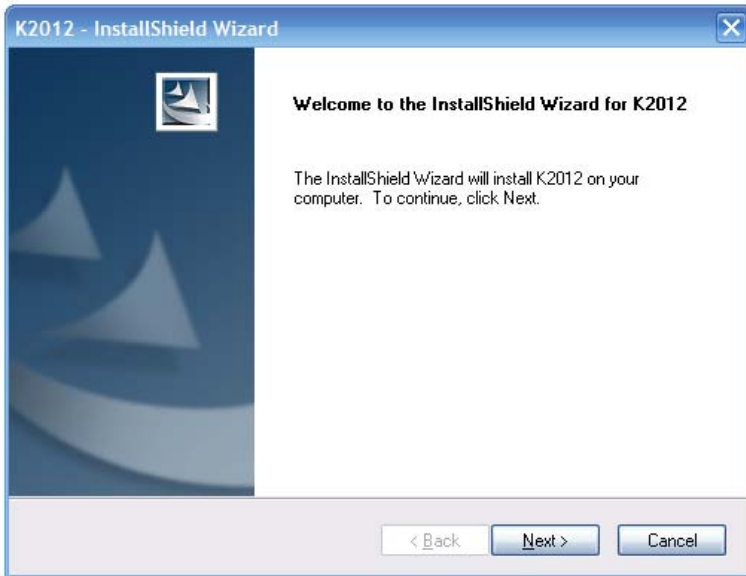

4. Select folder for installation, then click next

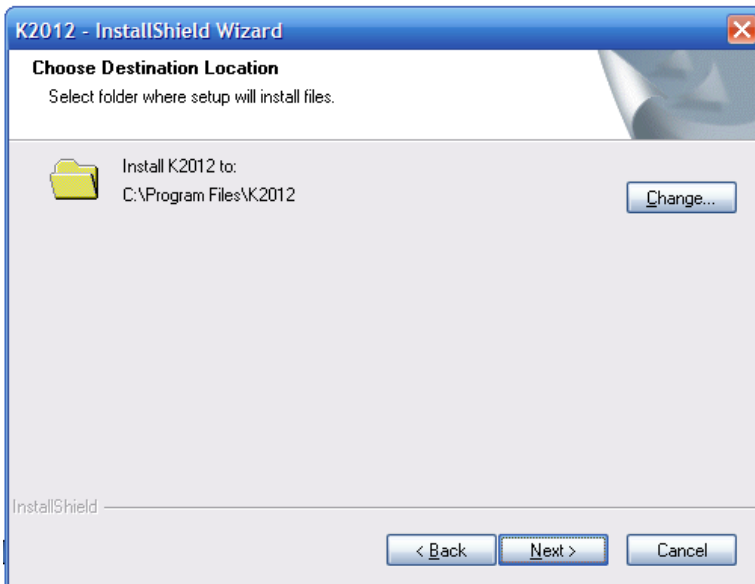

5. Click Install button to begin the installation, then waiting till installation finishes.

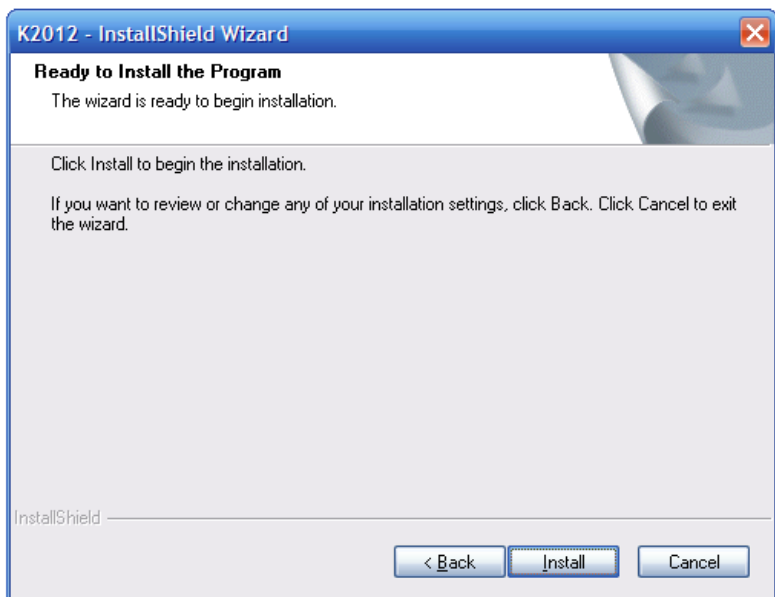

6. Then click Finish button to confirm it

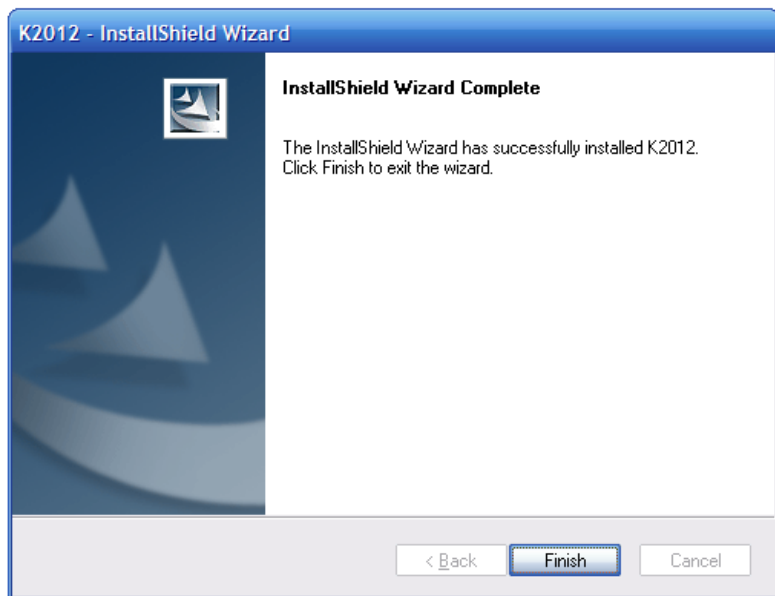

7. Please note the default login info:

ID: Device  
Password: 123456  
Server Name: Machine Name + '\\K2012'  
Database Name: K2012



## § 3.2. IP-Device Introduction

IP-Device is used to construct a new project and save project info to a database for IP-Agent whose info is based on the database.

Recommended Configuration Route:

Project Property -> IP Node Config -> Block Config -> Guard Centre Priority Setting -> Call Table for Blocks -> Call Table for Common Entrance -> Parameter Management for Blocks and Common Entrance

### IP Device Interface Instructions

#### 1. Project Property

Start the IP Device Software



Click the right mouse button on Default Project, then it will pop up a menu. Select Project Property

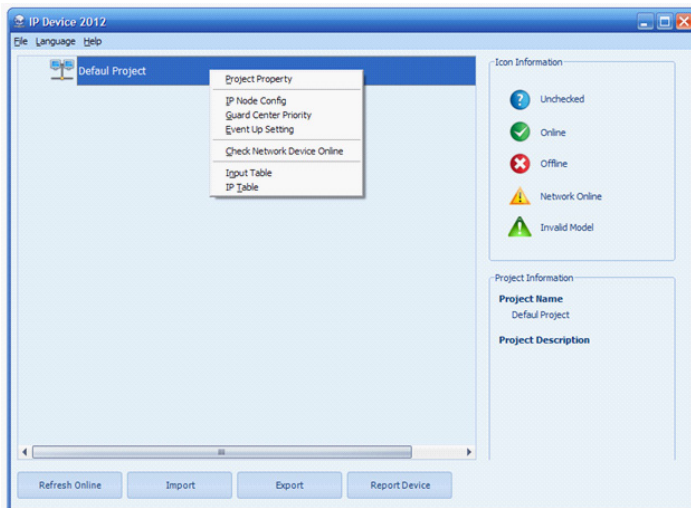

It will pop up a window for setting project property.

IP Seg: Select a IP Segment for the new project. We will take 192.168.0.X as an example in this manual\*

Project Name: Name the new project

Project Description: Can input some info about project

Project Mark: Can input some info about project

Insert time line: Insert created time in Project Mark frame.

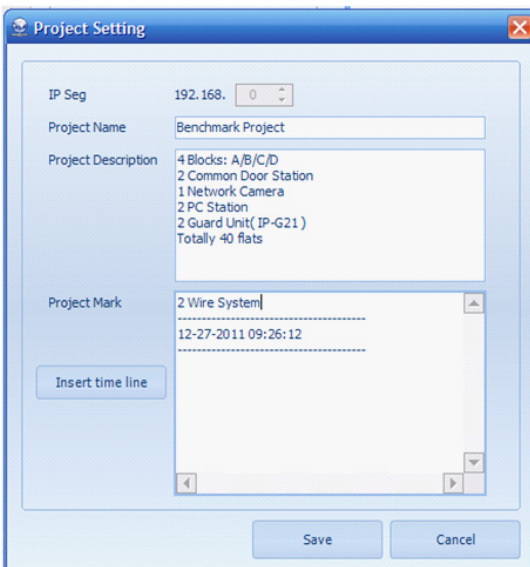
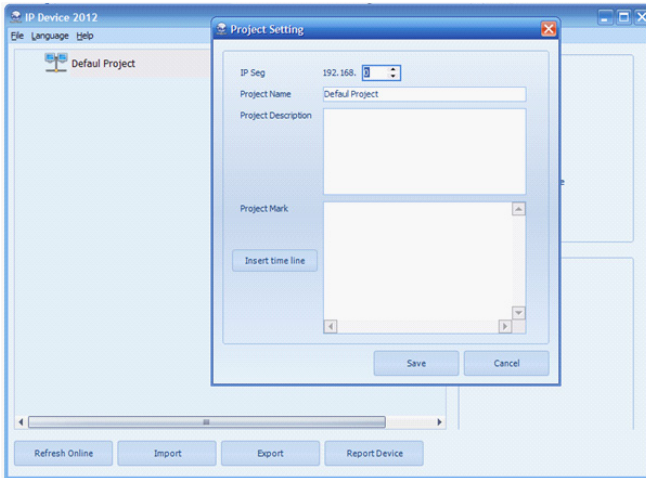

See the picture above, Benchmark Project is assumed a 2 wire/IP system.

Click Save button to save info when finish

\*Note that IP Seg just can be set at the first time. It's to say, IP segment isn't editable after first set.

## 2.IP Node Config

Click the right mouse button on Benchmark Project, then select IP Node Config. Select IP nodes which will be adopted in this project, select its model and name the device.

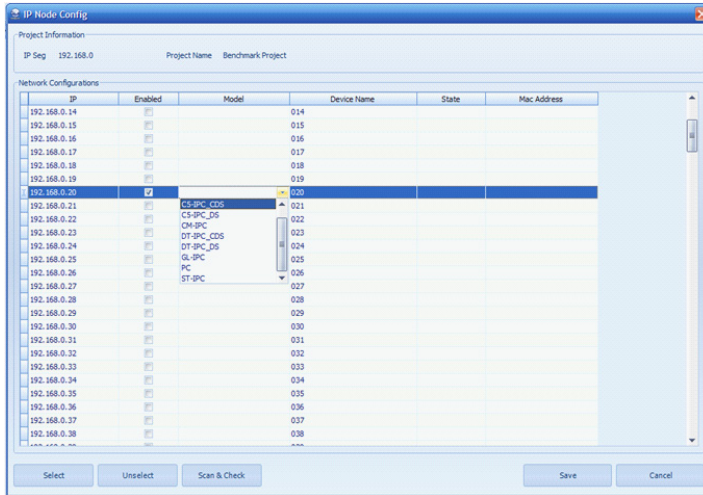

### IP Nodes Description

IP Nodes	Description
192.168.0.2 to 192.168.0.240	Door Station/Common Door Station/ Camera
192.168.0.241 to 192.168.0.246	PC Station( IP-Agent )
192.168.0.247 to 192.168.0.254	Guard Unit

### Model Description

Model Name	Model Description
C5-IPC_CDS	C5-IPC for Common Door Station
C5-IPC_DS	C5-IPC for Door Station
CM-IPC	IPC for CCTV Camera
DT-IPC_CDS	DT-IPC for Common Door Station
DT-IPC_DS	DT-IPC for Door Station
GL-IPC	Guard Unit
PC	PC Station( IP-Agent )
ST-IPC	IP8210



For example, in Benchmark Project, see the table, IP Nodes can be configured like the following picture

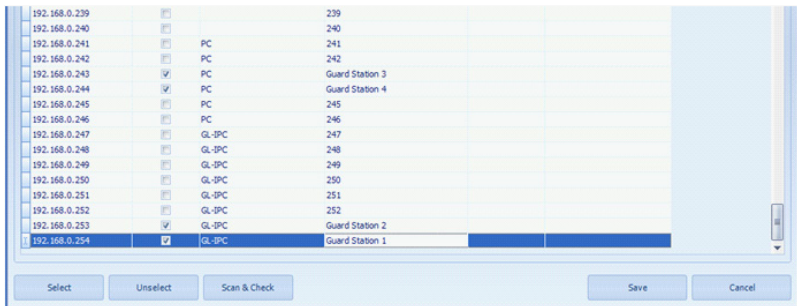
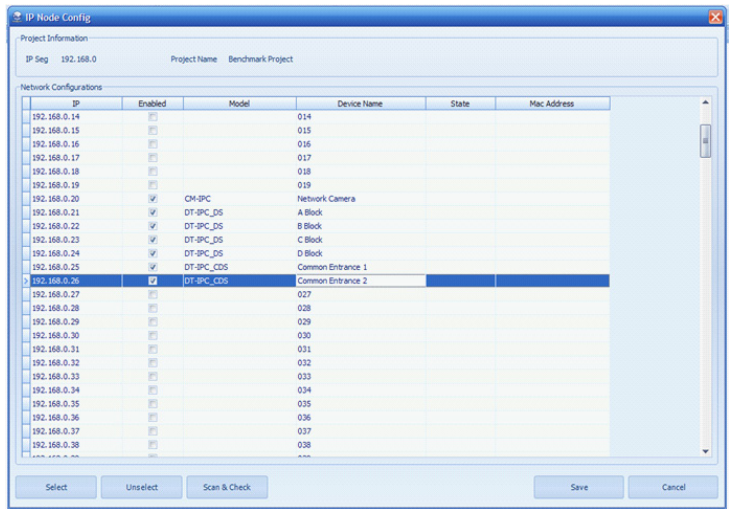

IP	Device
192.168.0.20	Camera
192.168.0.20 to 192.168.0.24	Door Station
192.168.0.25 to 192.168.0.26	Common Door Station
192.168.0.254 and 192.168.0.253	Guard Unit( IP-G21 )
192.168.0.243 and 192.168.0.244	PC Station( IP-Agent )

IP Node Config:

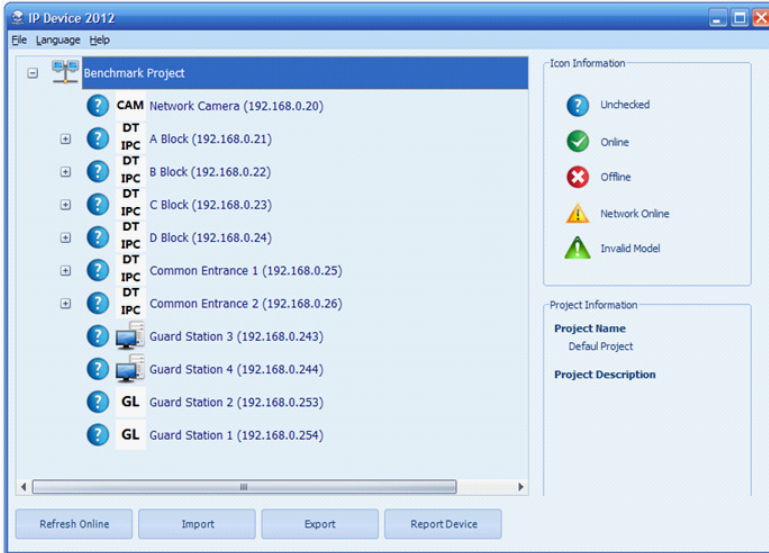

If all the device has been installed in the project, you can click the Scan & Check button to search if the selected IP Nodes are online. If not installed yet, click Save button to write the info to the database. Then main interface will show the devices like the following picture.



If you want to check if the devices are online, you can press Refresh Online button or click right mouse button on Benchmark Project then select Check Network Device Online. See the following picture,  means device offline, and  means PC is online, but IP-Agent isn't opened.  indicates the model of IP Node is wrong selected, or wrong DIP switch setting of IPC.

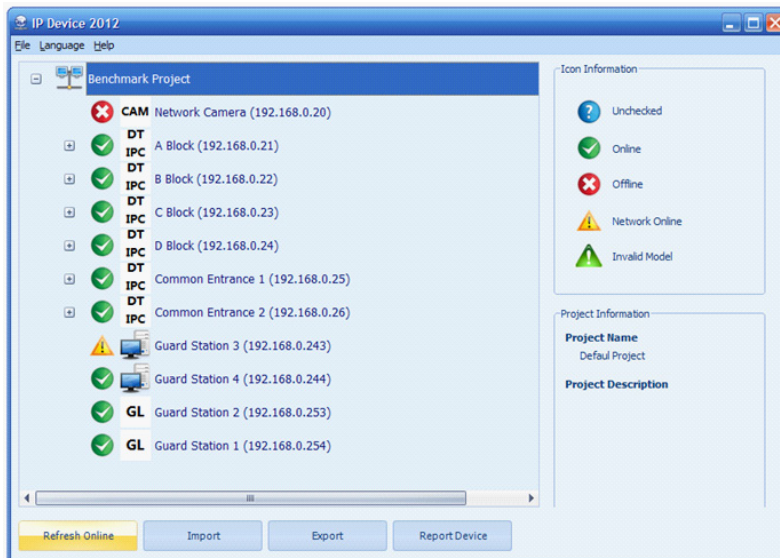

### 3. Block Config

Double Click A Block, you will find no door stations and monitors there. Door stations and monitors must be configured.

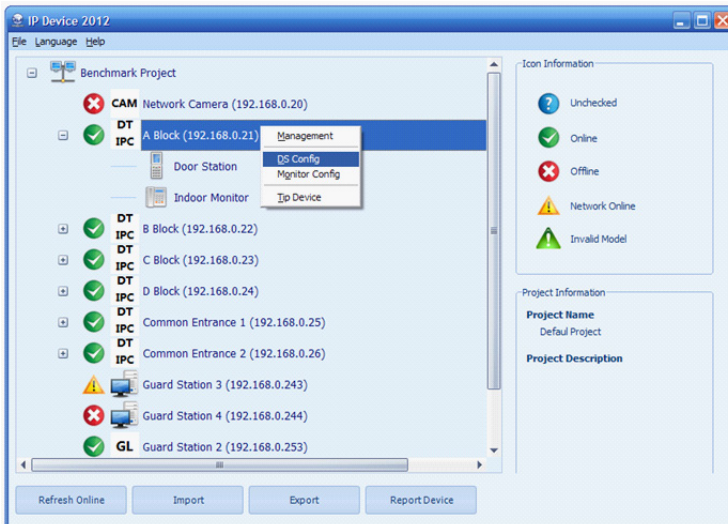
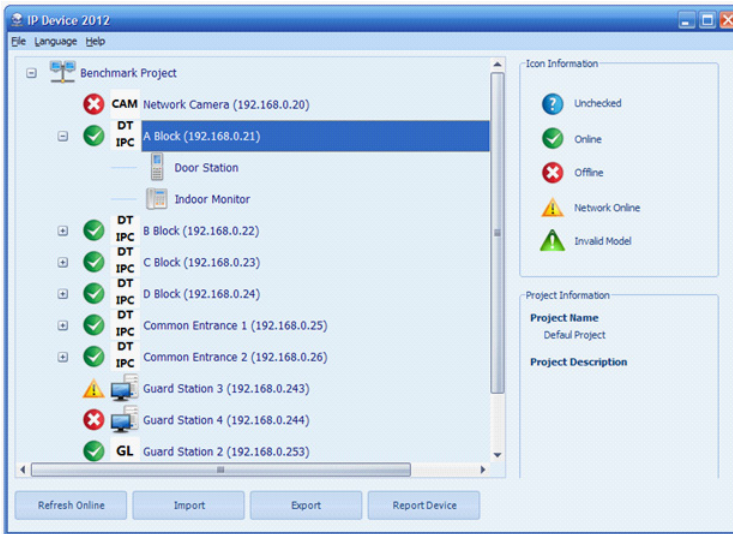

Take Benchmark Project as an example. There are 2 DT592 and 4 monitors in A blocks. User Codes of monitors are 00, 01, 02 and 03 respectively.

DS Config: Click the right mouse button on A Block -> Select DS Config on the pop-up window -> Config just like the following picture -> Click Save button to confirm -> Software will check if the door stations are online automatically.

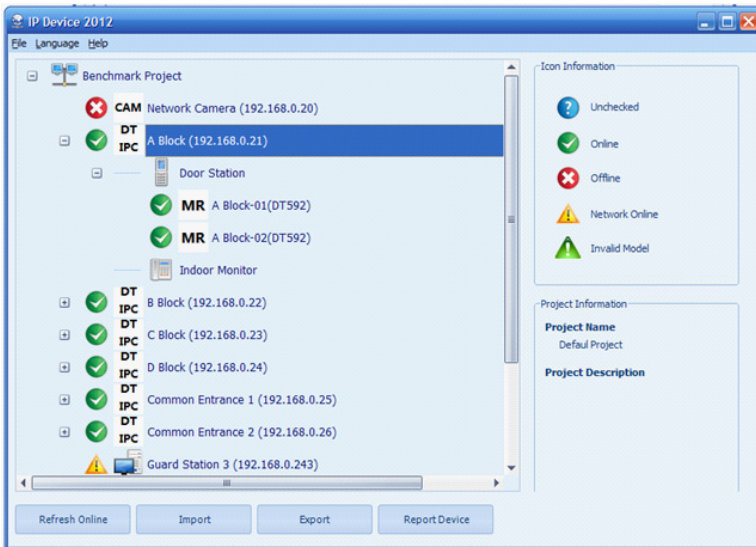
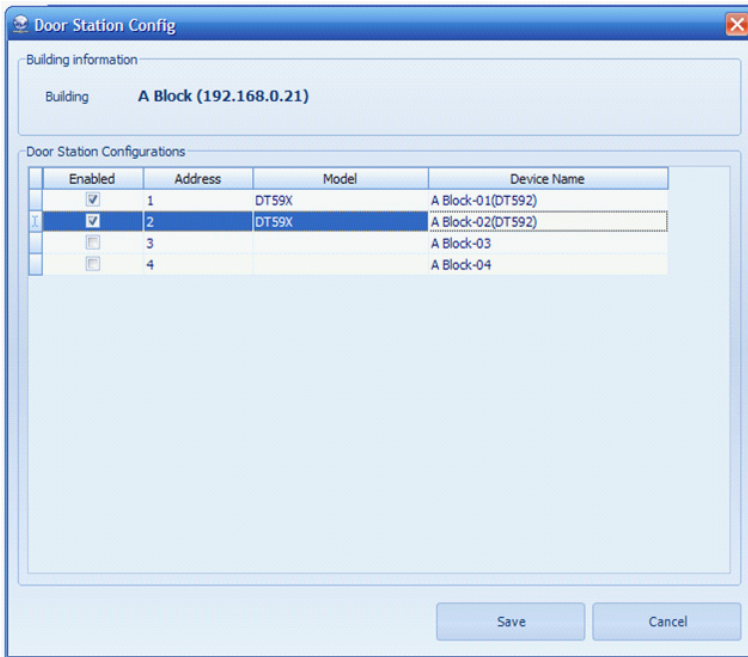

Monitor Config: Click the right mouse button on A Block -> Select Monitor Config on the pop-up window -> Config just like the following picture -> Click Save button to confirm -> Software will check if the monitors are online automatically.

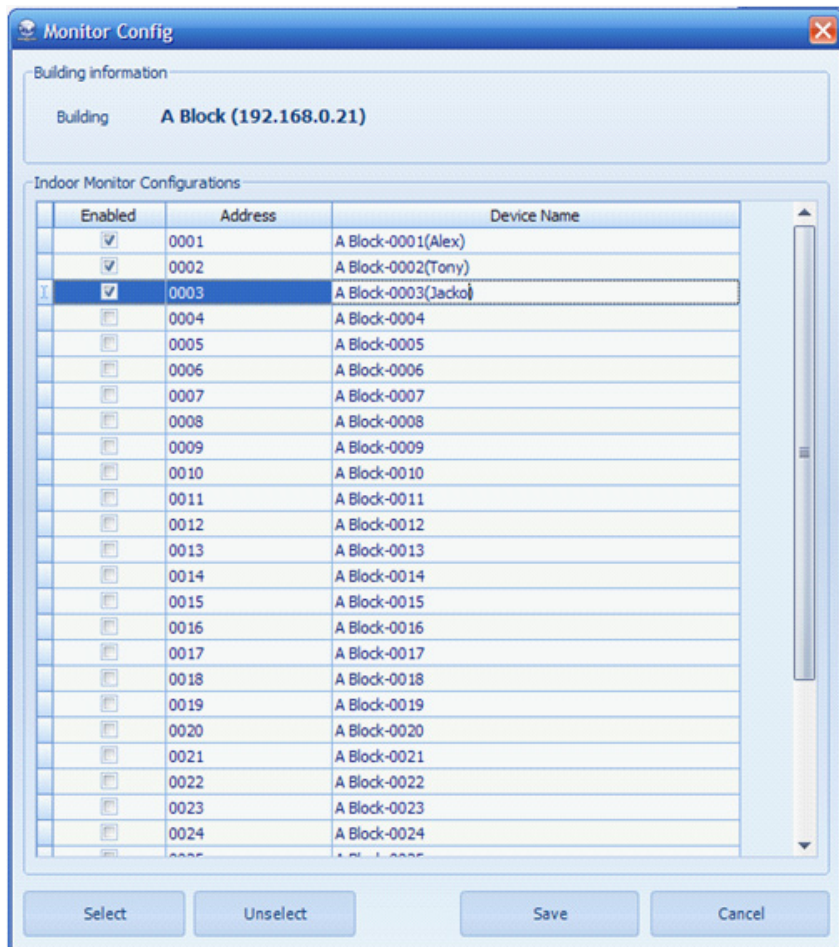

Note that 0032(User code) is equal to 0000 when door station is DT592 or DT596

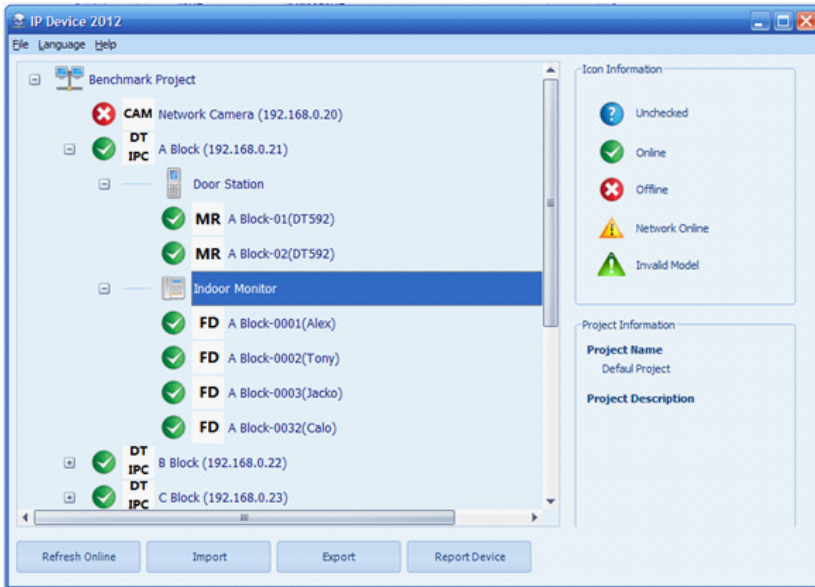

DS and Monitors Config of other blocks in Benchmark Project can use the same method to config.

#### 4. Guard Centre Priority Setting

This setting is configured for guard centre( PC Station and Guard Unit) priority.

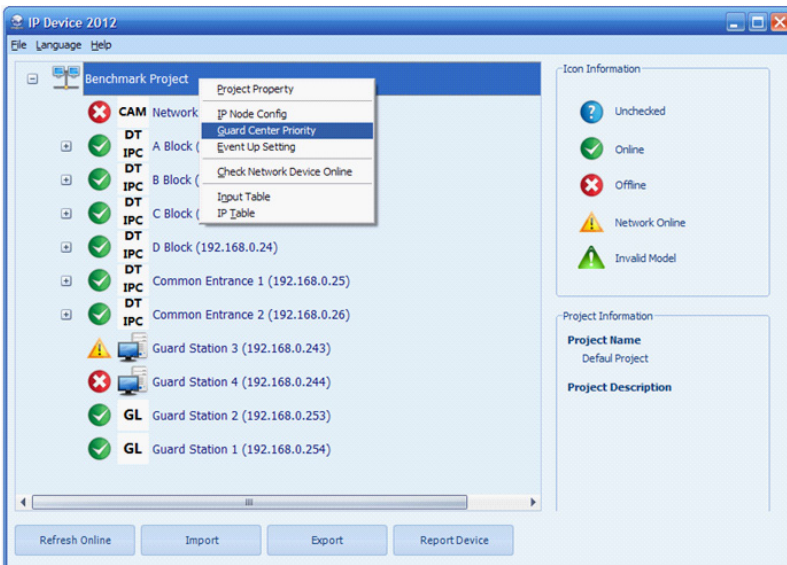

See the following picture, there are 8 position for calling transfer. For example, when one door station or monitor call Guard Centre, it will call GL 1 firstly, if GL 1 is busy or offline, the calling will be diverted to GL2, if GL2 is busy or offline, the calling will be diverted to GL 3... Repeat this till divert the calling to the last Guard Centre.

**Guard Center Priority**

Default GL Input:

**The order of default GL call transfer**

GL 1	None
GL 2	None
GL 3	None
GL 4	None
GL 5	None
GL 6	None
GL 7	None
GL 8	None

Write to all device Save Cancel

**Guard Center Priority**

Default GL Input:

**The order of default GL call transfer**

GL 1	Guard Station 1 (192.16)
GL 2	Guard Station 2 (192.16)
GL 3	Guard Station 3 (192.16)
GL 4	Guard Station 4 (192.16)
GL 5	None
GL 6	None
GL 7	None
GL 8	None

Write to all device Save Cancel

Press the Write to all device button to download the info to all devices connected to the network, and info will be saved to database at the same time. If only press Save button, the info just is kept in the database, isn't downloaded to devices.

## 5. Call Table For Blocks

For DT-IPC of blocks, there is 2 call tables for calling guard station: Button Call Table and Call Priority.

The route for Call Table(Take B Block as an example): Click right mouse button on B Block -> Management -> Call Table, see the following picture, both of them have 2 buttons, View & Edit and View On Device. Press View & Edit, you can view the table in the database and edit, then can download the edited table to the corresponding DT-IPC. Press View On Device, you can check the call table in the corresponding DT-IPC.

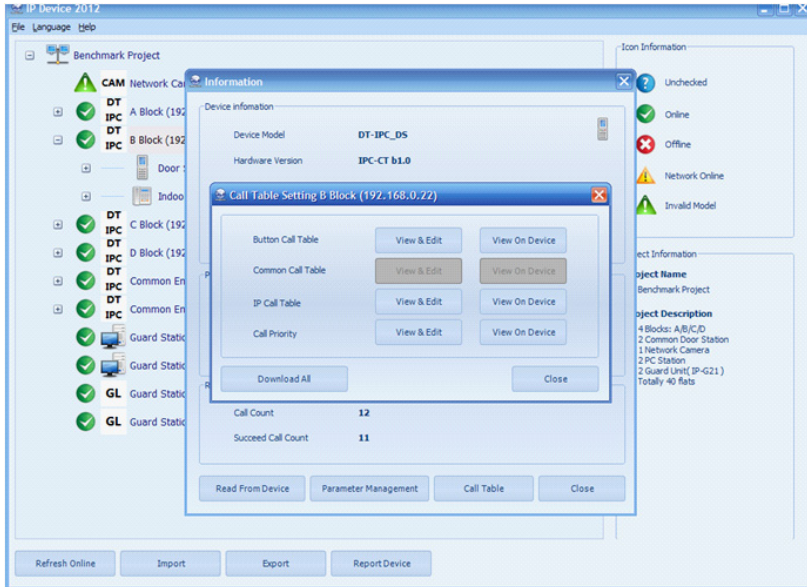

**Button Call Table:** This table is for door station and monitors calling guard centre

The table is actually a Mapping between Guard Centre and Door station/Monitor.

It's to say:

For door station, press the specified button(DMR11) or input the specified No.(DMR18) to call the corresponding Guard Centre.

For Monitors, press the specified No. in the Namelist to call the corresponding Guard Centre.

### 1) View & Edit

Click Add Guard Centre button to pick one Guard Centre for 32



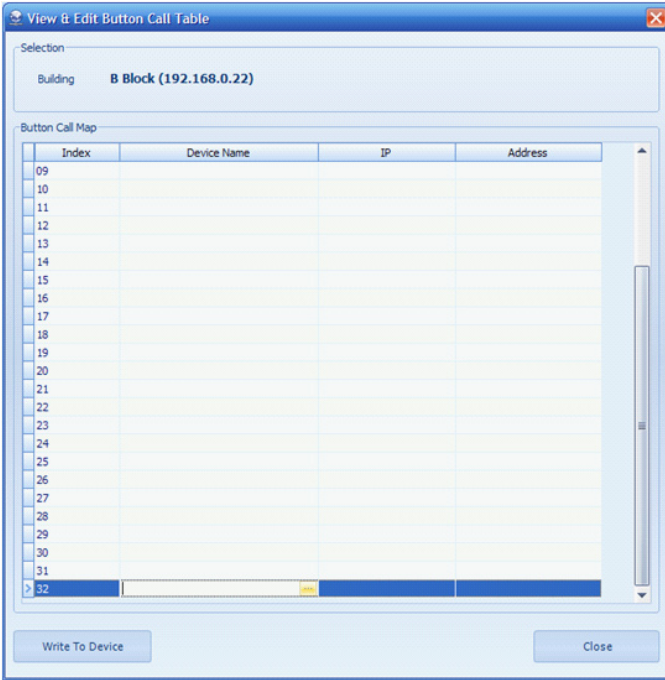

Pick one Guard Centre for 32, then press ok button

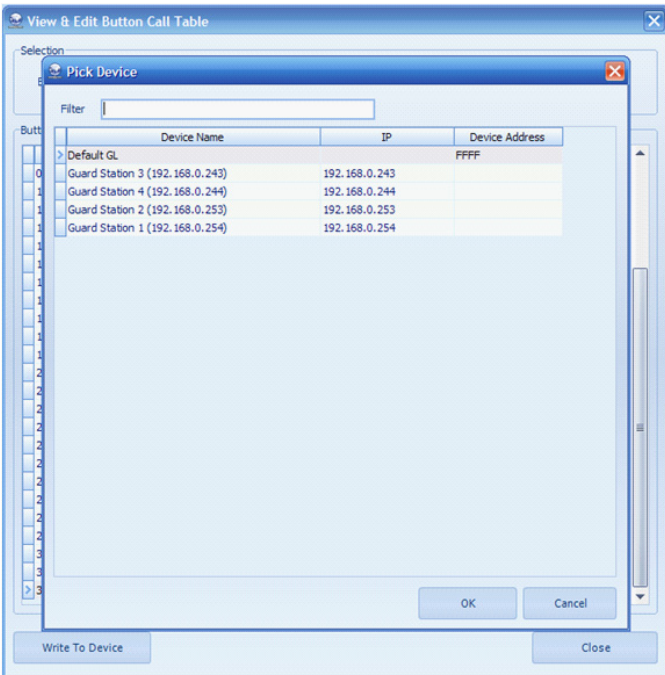

If you want to cancel the mapping between call No. and Guard Centre, press the Delete Guard Centre button

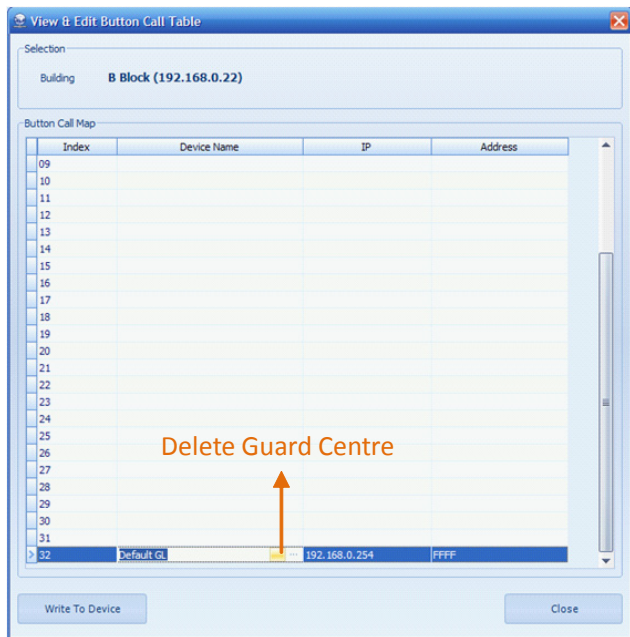

Repeat the similar operation to fulfill the mapping between call No. and Guard Centre.

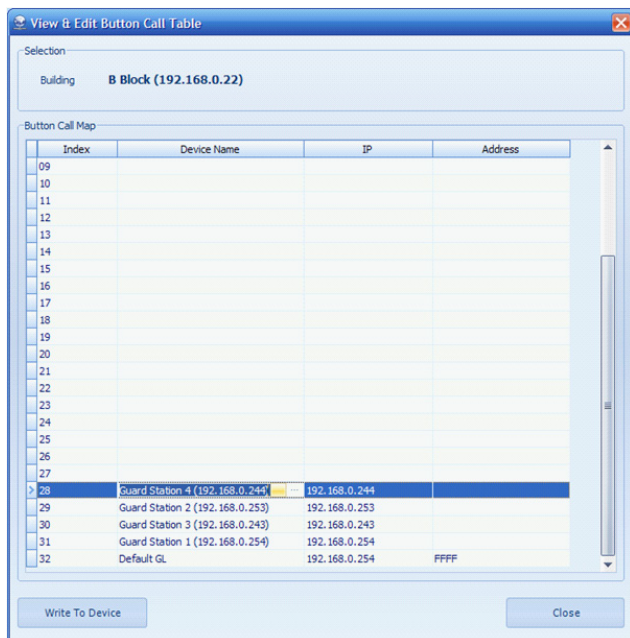

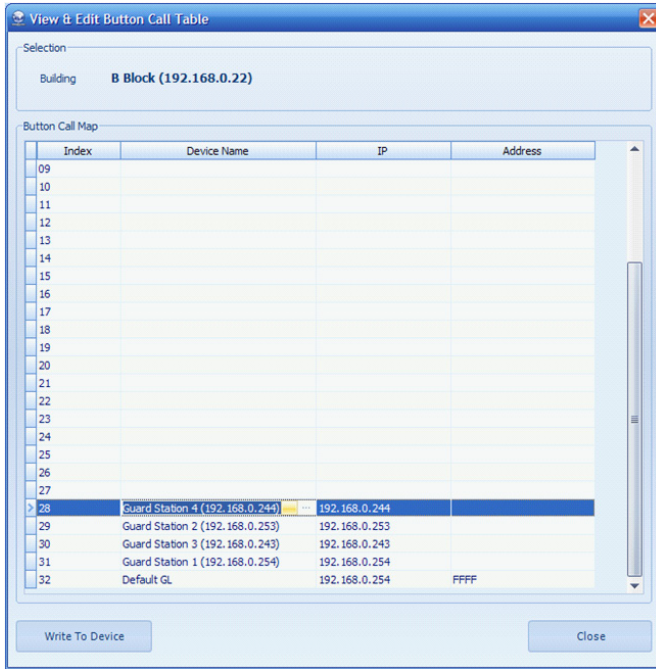

Press the Write to Device button to save and download to the corresponding DT-IPC after finish.

The below table is the description for the mapping

Index	Device Name	Direct Button Door Station(DMR11/D8 + EP24)	Digital Input Door Station(DMR18)	Namelist in Monitor	Calling Diversion
28	Guard Station 4 (192.168.0.244)	Specified Button. 28th button by default	28	28	No
29	Guard Station 2 (192.168.0.253)	Specified Button. 29th button by default	29	29	No
30	Guard Station 3 (192.168.0.243)	Specified Button. 30th button by default	30	30	No
31	Guard Station 1 (192.168.0.254)	Specified Button. 31st button by default	31	31	No
32	Default GL	Specified Button. 32nd button by default	32	32	Yes

Note that: for the above example, press 32 to call Default GL, calling can be diverted when destination is busy or offline. The called Guard Centres and diverting order depend on the info that had been stored in the corresponding DT-IPC. Press View on Device of Call Priority to view the Guard Centre Priority. The operation for Guard Centre Priority will be introduced in the next part.

## 2) View On Device

You can check the info in the DT-IPC by pressing the View On Device button

Continue previous operation, press the View On Device after Write to Device operation. The table is as follow:

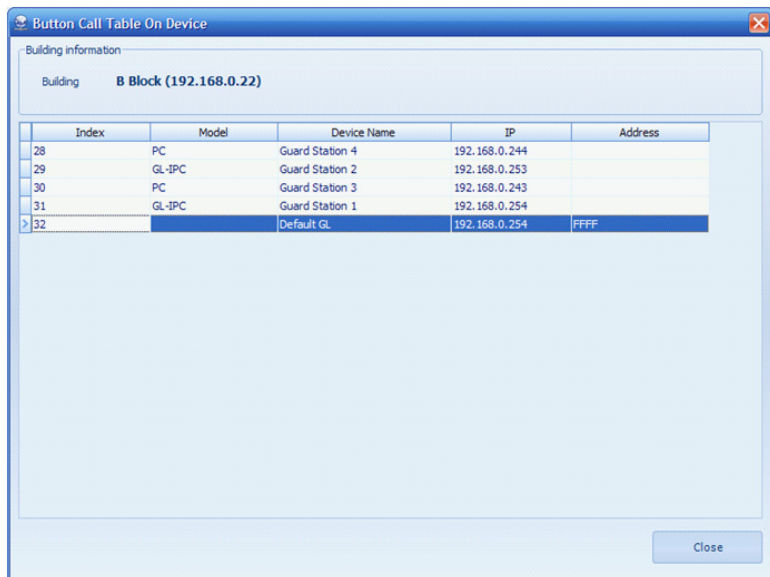

Index	Model	Device Name	IP	Address
28	PC	Guard Station 4	192.168.0.244	
29	GL-IPC	Guard Station 2	192.168.0.253	
30	PC	Guard Station 3	192.168.0.243	
31	GL-IPC	Guard Station 1	192.168.0.254	
32		Default GL	192.168.0.254	FFFF

## Call Priority

This Call Priority operation is only for the corresponding DT-IPC.

Because we can download the default Guard Center Priority to all the DT-IPC in the Global Setting( eg. Click right mouse button on Benchmark Project -> Guard Center Priority), you should firstly press the View On Device to check if the priority setting is ok. If not, press View & Edit button entry the setting.

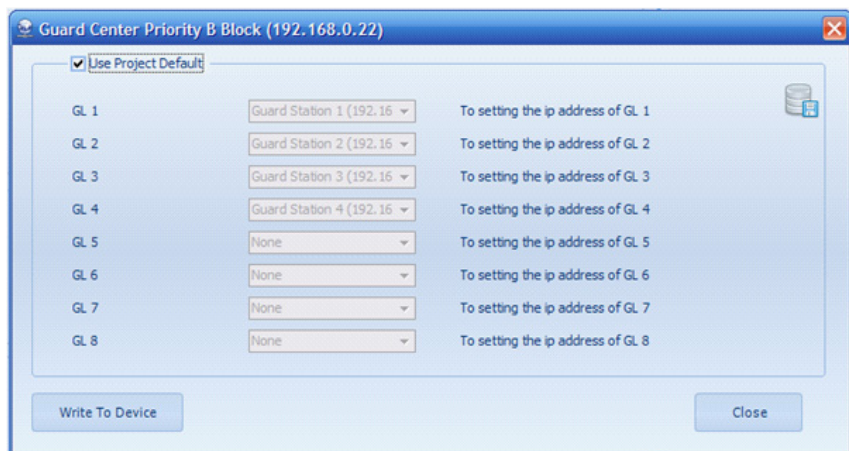

If you don't want to use the Default setting, deselect the Use Project Default item, and then edit the private calling diverting order for the corresponding DT-IPC. Press write To Device button to download the info to the corresponding DT-IPC.

Click the Download All button to download Button Call Table, IP Call Table and Call Priority at one time.



## 6. Call Table for Digital Input Common Entrance Panel(DMR18)

192.168.0.25 had been configured to be CDS(Common Door Station) in IP Node Config Chapter.

Assume that DMR18 had been connected to this DT-IPC.

For Digital Input Common Door Station(DMR18), only Common Call Table and Call Priority should be cared about. For Call Priority setting is similar to call Priority section in Call Table for Blocks chapter, this chapter just focus on Common Call Table.

Click right mouse button on Common Entrance and select Management, then select Call Table button into the following interface. Note that Common Call Table is equivalent to Input Table in the project submenu(The pop-up menu when click right mouse button on Benchmark project)



The default rule for digital input common door station calling monitors is 'IP Node' + 'User Code'.

If the default calling rule can meet project requirement, only guard center calling rule is need to be configurated. If not, both of guard center and monitor calling rule must be configurated.

## Mapping Rule

\* Using Default Rule to call Guard Unit and monitors. For example, press 254-01 to call Guard Station 1, press 243-01 to call Guard Station 3, press 024-15 to call the monitor whose user code is 15 in D block.

\* New rule for Mapping between Common Entrance and monitors

IP	Address	Model	Device Name	CDS Input
192.168.0.23	0008	Monitor(DT)	C Block-0008	003-08
192.168.0.24	1	DMR 115,D(ID)	D Block-01(DMR 11)	
192.168.0.24	0009	Monitor(DT)	D Block-0009	004-01
192.168.0.24	0010	Monitor(DT)	D Block-0010	004-02
192.168.0.24	0011	Monitor(DT)	D Block-0011	004-03
192.168.0.24	0012	Monitor(DT)	D Block-0012	004-04
192.168.0.24	0013	Monitor(DT)	D Block-0013	004-05
192.168.0.24	0014	Monitor(DT)	D Block-0014	004-06
192.168.0.24	0015	Monitor(DT)	D Block-0015	004-07
192.168.0.24	0016	Monitor(DT)	D Block-0016	004-08
192.168.0.24	0017	Monitor(DT)	D Block-0017	004-09
192.168.0.24	0018	Monitor(DT)	D Block-0018	004-10
192.168.0.24	0019	Monitor(DT)	D Block-0019	004-11
192.168.0.24	0020	Monitor(DT)	D Block-0020	004-12
192.168.0.24	0021	Monitor(DT)	D Block-0021	004-13
192.168.0.24	0022	Monitor(DT)	D Block-0022	004-14
192.168.0.24	0023	Monitor(DT)	D Block-0023	004-15
192.168.0.24	0024	Monitor(DT)	D Block-0024	004-16
192.168.0.25	1	DMR 18	Common Entrance 1-01(DMR 18)	
192.168.0.26	1	DMR 115,D(ID)	Common Entrance 2-01(DMR 11)	
192.168.0.243		PC	Guard Station 3	000-03
192.168.0.244		PC	Guard Station 4	000-04
192.168.0.253		GL-IPC	Guard Station 2	000-02
192.168.0.254		GL-IPC	Guard Station 1	000-01

As the above CDS Input, for example, press 004-07 to call the monitor whose user code is 15 in D block after the rules are download to device.

## 7. Call Table for Direct Button Common Entrance Panel(DMR11)

For Direct Button Common Door Station, only Button Call Table and Call Priority should be cared about. For Call Priority setting is similar to call Priority section in Call Table for Blocks chapter, this chapter just focus on Button Call Table.

192.168.0.26 had been configured to be a CDS(Common Door Station) in IP Node Config Chapter. Assume that DMR11/D8 and EP24 had been connected to this DT-IPC.

Click right mouse button on Common Entrance and select Management, then select Call Table button into the following interface.



Press View & Edit of Button Call Table tab to edit the calling mapping, just like the following picture.

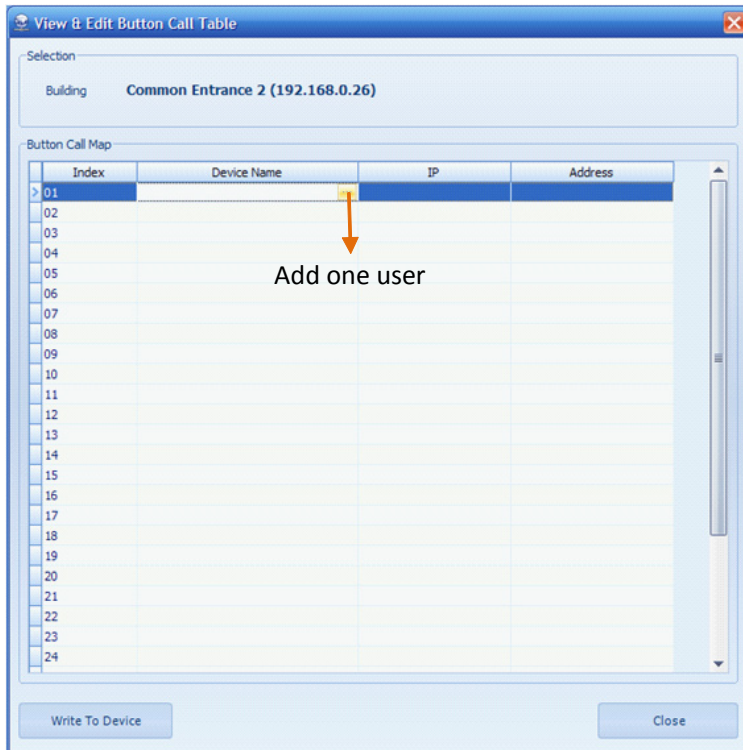



It will pop up a window for you to pick a user. Just like the following picture

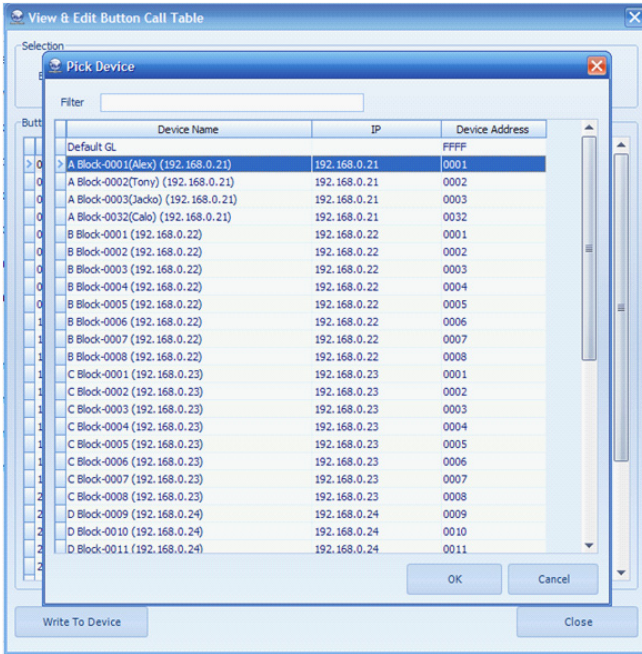

The picture just as following picture

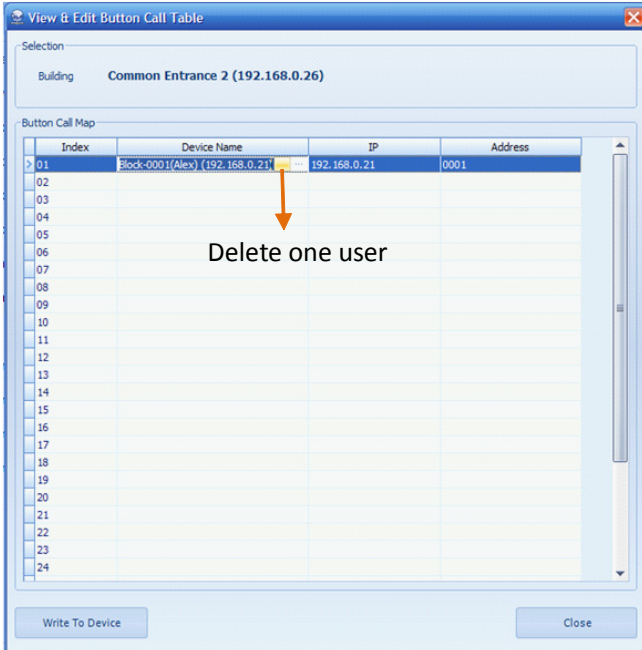

Fulfill the call table, then press Write To Device to download the info to the corresponding DT-IPC. You can call user or Guard Center by the corresponding button, for example, press 32nd button to call Default Guard Center, press 20th button to call the monitor whose user code is 15 in D block.

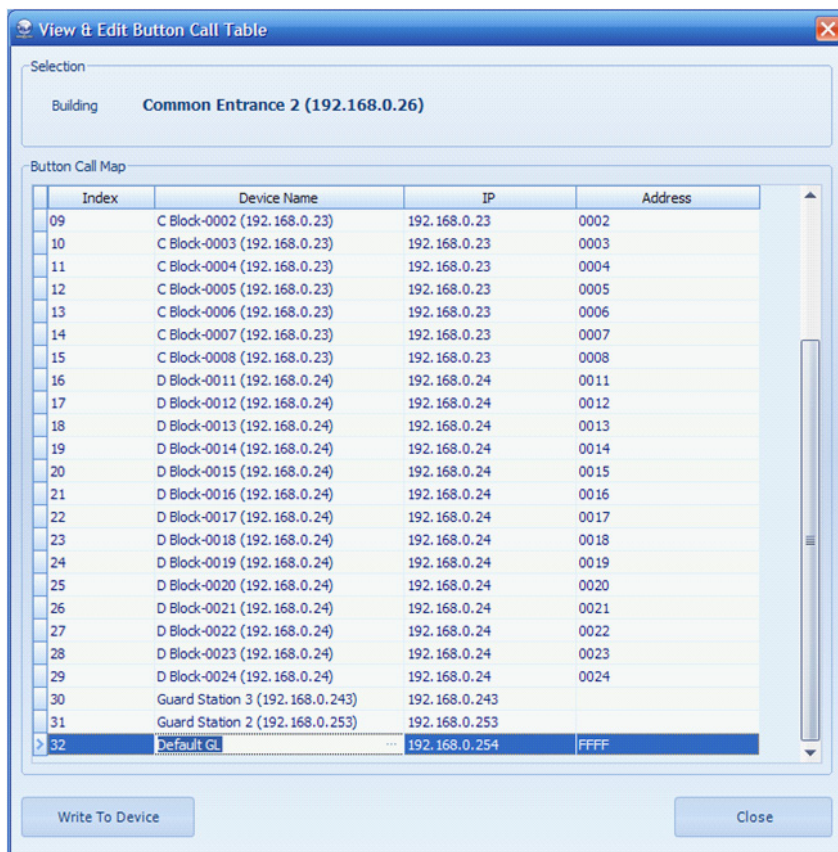

## 8. Parameter Management for Blocks and Common Door Station

Because the item meanings of parameter management for blocks and common door station are the same. So just take B Block of Benchmark Project as an Example

Click right mouse button on B Block, select Management, then select Parameter Management in next page. Then it will pop up Parameter Management page

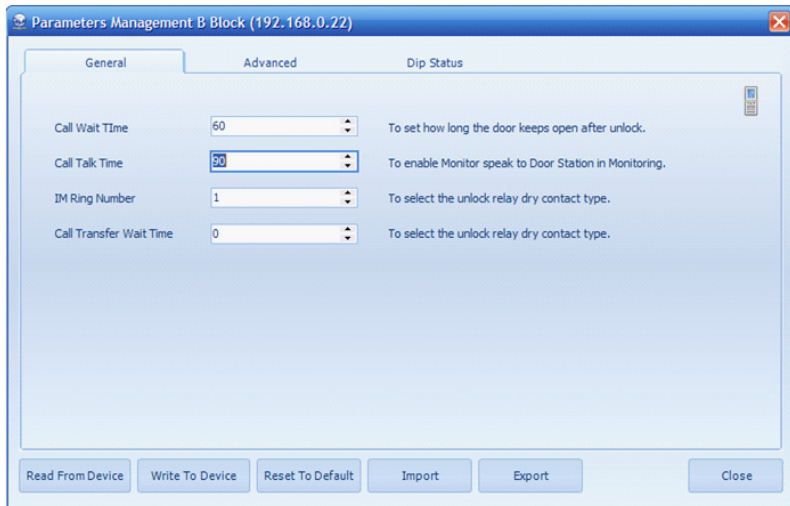

### Button Description:

**Read From Device:** Read all the info stored in the device

**Write To Device:** Write all the info to the device

**Reset To Default:** Reset all the info in the database to Default(Note that the operation is for database in PC, if you want to reset the device info, press Reset To Default and then press Write To Device)

**Import:** Import a parameter file that has been saved before to reset the info.

**Export:** Export a parameter file to backup the current info.

**Close:** Close the Parameter Management page

### General Setting Description:

**Call Wait Time:** To set calling waiting time for door station and monitor. Range from 10 to 600s.

**Call Talk Time:** To set limitation for talking time. Range from 10 to 600s

**IM Ring Number:** To set the ring times for monitor when called. Range from 1 to 4

**Call Transfer Wait Time:** To set waiting time before diverting calling to next Guard Center

### Advanced Setting Description

#### a. Call Priority

To set priority for different calling. Range from 1 to 4, 1 is the lowest priority, and 4 is the

highest one.

**GL Call IM:** To set Priority for Guard Center calling indoor monitor.

**CDS Call IM:** To set Priority for Common Door Station call indoor monitor.

**DS Call IM:** To Set Priority for door station call indoor monitor

### b. 8210 Control

**IP-8210 Reset Check Number:** If DT-IPC had been detected offline N times, start power-down mode. To set the N value.

**IP-8210 Power Cut Time:** Timing for power-down when reset DT-IPC

**IP-8210 Reset Count:** Counting for DT8210 resets

### c. Call Table Quan

**Rows of Common Call Table:** To set rows of common call table. Default is 110.

**Rows of IP Table:** To set rows of IP Table. Default is 32.

**Rows of Room Call Table:** To set rows of Room Call Table. Default is 32.

Section	Parameter	Value	Description
Call Priority	GL Call IM	1	To set Limitation of Monitoring operation.
	CDS Call IM	1	To set called Monitor's wait and ring time.
	DS Call IM	1	To set Limitation of Monitor's talking operation.
8210 Control	IP-8210 Reset Check Number	3	IP-8210连续N次检测高线,启动断电
	IP-8210 Power Cut Time	3	IP-8210断电复位时,断电的时间
	IP-8210 Reset Count	0	IP-8210断电复位时,断电的时间
Call Table Quan	Rows of Common Call Table	110	To set Limitation of Monitoring operation.
	Rows of IP Table	32	To set switch time when multi Door Stations are installed.
	Rows of Room Call Table	32	To set called Monitor's wait and ring time.

## DIP Status

The DIP Status page is used to show the DIP status of SW201 in DT-IPC.

DIP	OFF	ON
1	Reserved	Reserved
2	Other DS	DT591/DT592
3	Local Guard Center	Network Guard Center
4	Door Station	Common Door Station

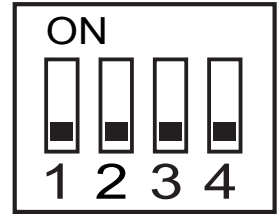

### Dip Status page Description

**Guard Center:** To show the 3rd DIP status of SW201, Local Guard Center or Network Guard Center. Local Guard Center stands for DIP OFF, press Direct Call Guard Unit button in the intercom menu of monitor to call monitor who is used as one local guard center. Network Guard Center stands for DIP ON, press Direct Call Guard Unit button to call Guard Center, PC station or Guard Station.

**DS Work Mode:** To show the 2nd DIP status of SW201, DT591/DT592 or other door station. If it shows DT591, it stands for DIP ON. In this status, when calling the monitor whose user code is 00/32 by Guard Center or Common Door Station, monitors whose user codes are in the range of 1 to 15 will respond the calling as slave monitors. If it show other, no such a function.

**Work Mode:** To show the 4th DIP status of SW201, Door Station or Common Door Station. If it shows Door Station, door stations works as a door station, or else, works as a common door station.

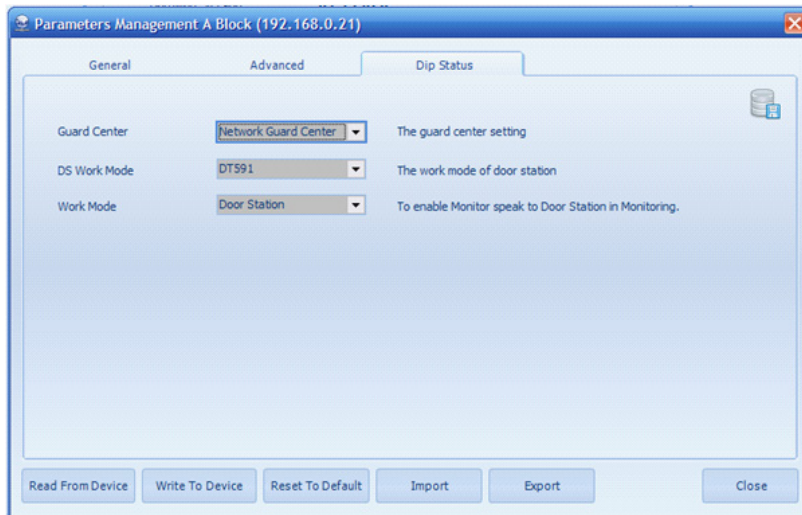

### 3.3.1 Overview

#### What's IP-Agent

IP-Agent is one part of PC Station. It's a guard center that enables you communicate with user, entrance of blocks, common entrances and other guard centers in one residential area via IP network.

Unlock door when talking with entrances or monitoring.

Capture picture of entrances when monitoring or calling entrances

Record video automatically when incoming calling from entrances

Record video manually when monitoring or calling entrances

#### Concepts

**Device:** Including PC Station, Guard Station, Common Door Station, Door Station, Monitors and Network Camera

**IP Device.exe:** IP Device.exe is used to configured device for IP-Agent.

**GL:** Guard Station, eg. IP-G21, used to call entrances and users. It can monitor/unlock entrances too.

**PC:** IP-Agent, including the same function to GL, but it can record video and capture picture besides above-mentioned function.

**DS:** Door Station, A device is installed in front of block entrance to call flats or Guard Centers.

**CDS:** Common Door Station, installed in the entrances of residential area to call users and Guard Centers.

**IM:** Indoor Monitor.

**IP Node:** The IP address of device.

#### Key Features of IP-Agent

##### Monitor Viewer

- Show all the devices that have been configured by IP-Device.exe, Including lists of Guard Centers, CDS & DS, monitors and network camera
- Show the device name and its IP Node.
- It will pop up a new window for operation when calling.
- Unlock DS & CDS when calling and talking

- Capture picture of DS & CDS when monitoring, calling and talking manually.
- Record video of DS & CDS when monitoring calling and talking manually
- Record video automatically when incoming calling from DS & CDS, optional
- Transmit Video of related camera to monitor when calling user, optional
- Monitor up to 12 devices(CD/CDS) simultaneously
- Monitoring can be activated automatically when IP-Agent gets start.
- Support two kind of pixel aspect ratios formats, 4:3 and 16:9
- Support full screen mode.

### **Call List**

- Record info of all the calls, incoming calls and missed calls

### **Alarm**

- Record info of all the alarm and events

### **Record Viewer**

- Replay audio and video records

### **Capture Viewer**

- Replay captured picture

### **Setup**

- General Setting: Camera IP function, files path located for captured pictures and video records, language selection, video type, max time for calling and monitoring.
- Alarm setting: Name alarm regions, set alarm sound
- View & Layout: Set max channel for monitoring, select DS/CDS to monitor automatically when IP-Agent get starts, view info
- Handset usage setting, optional

## **3.3.2 IP-Agent Description**

On your desktop, click the program icon that has been created automatically. IP-Agent gets starts.

## Login

To Access IP-Agent, you must log in with a registered account at first

1. On your desktop, double click the IP-Agent icon,the login dialog should appear.

2. Provide the user ID and password

Default ID: device

Default Password: 123456

3. Provide the Server name and Database Name

Server name: machine name + 'K2012'

Database Name: K2012



\* The default password can be exposed to a hacking thread so it is recommended to change the password by IP-Admin software after installing the product.

Note that the security and other related issues caused by the unchanged password shall be responsible for the user.

\* The following is an example of login failure, if you input an incorrect ID or password, you will see the error message.



The following is another example of login failure, if you input an incorrect Server Name or Database Name, you will see the error message.





## IP-Agent at a Glance

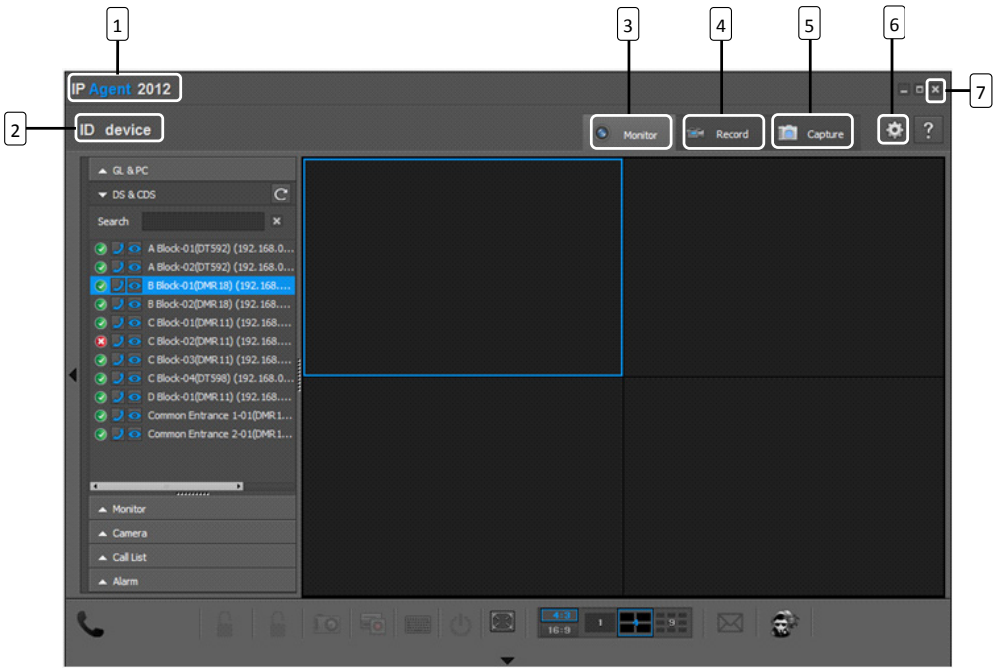

Item	Name	Description
1	S/W Title Bar	Display the name of the software
2	ID	Shows the user ID
3	Monitor	Launches the Monitor Viewer.
4	Record	Launches the Record Viewer
5	Capture	Launches the Capture Viewer
6	Setup	Open the setup page
7	Exit	Terminates the application

### 3.3.3 Monitor Viewer

From the top right corner of the IP-Agent main screen, click the [Monitor] tab.

## Name and Fuction of each Item in Monitor Viewer

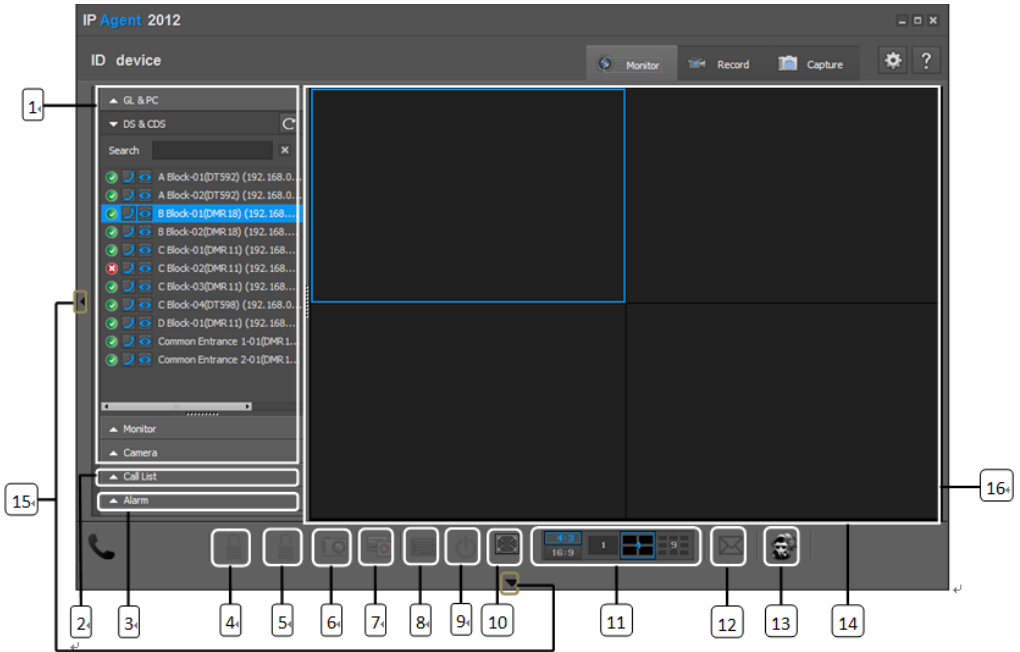

Item	Name	Description
1	Device List	Consists of 4 parts: GL&PC, DS&CDS, Monitor&Camera
2	Call List	Call info record
3	Alarm	Alarm and events record
4	Unlock 1 *	Unlock the first latch of the entrance
5	Unlock 2 *	Unlock the second latch of the entrance
6	Capture	Capture a picture of the selected video window
7	Record	Performs/Stop Recording the selected video window
8	Digital Keypad	Open digital keypad for operation
9	Exit	Exit monitoring
10	Maximum	Maximize the monitoring screen
11	Aspect Ratio	Select an aspect ratio and a number of split screen
12	Reserved	Reserved
13	Reserved	Reserved
14	Monitor Screen	Displays the monitor viewer screen
15	Adjust Window Button	Displays or hides the menu window
16	Video Screen	Displays monitoring video

\*Note that Unlock 1 and Unlock 2 buttons can unlock the 1st and 2nd latches respectively if door station model can connect two latches. Both of Unlock 1 and Unlock 2 buttons can unlock the latch if door station model can only connect one latch

### Name and Function of each Item in the the Monitor Window



Item	Name	Description
1	Monitor Time	Displays the monitor time
2	Device Name	Displays the name of the monitored device

### Name and Function of each Item in the Pop-up Calling Window

It will pop up a calling window for video and operation when there is a calling to DS/CDS or an incoming calling from DS/CDS









Item	Name	Description
1	Capture	Capture a picture of the video window
2	Record	Performs/Stop recording the video window
3	Unlock 1	Unlock the first latch of the entrance
4	Unlock 2	Unlock the second latch of the entrance
5	Speaker Volume	Adjust speaker volume via up and down button
	Mic Volume	Adjust mic volume via up and down button
6	Exit	Exit the communication window
7	Maximum	Maximize the video window

## Device List

Device List consists of 4 parts, including GL & PC, DS & CDS, Monitor and Camera.

After device configuration operation in IP Device software, all the devices that have been configured in IP Device will shown in the Device List.

Icons & Description:

1. :  Device Online
2. :  Device Offline
3. :  PC Online, but IP-Agent doesn't open
4. :  Invalid Model
5. :  Call
6. :  Monitor

### a. GL & PC

GL & PC is a list of Guard Centers, including Guard Station and IP-Agent. In the GL & PC frame, you can see other Guard Center status.

Press  button to refresh Guard Center status

Press  button to call the related Guard Center

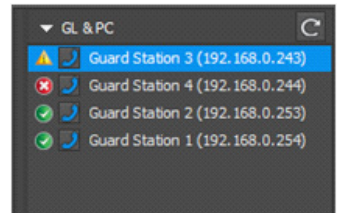

\* Call

It will pop up a calling window when calling a Guard Center. Press  button to exit the calling window.

Call Succeed:

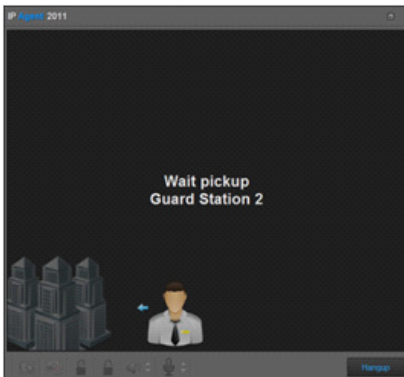

1) Call and wait for picking up

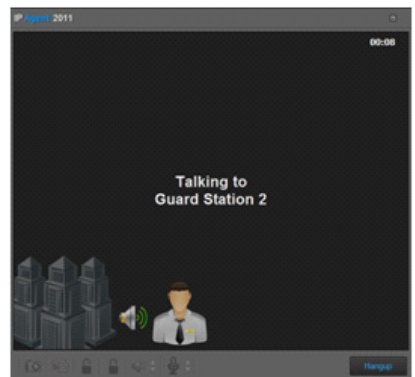

2) Talking established if the called Guard Center picks up

Call Failure: \*

Detail refers to trouble shooting

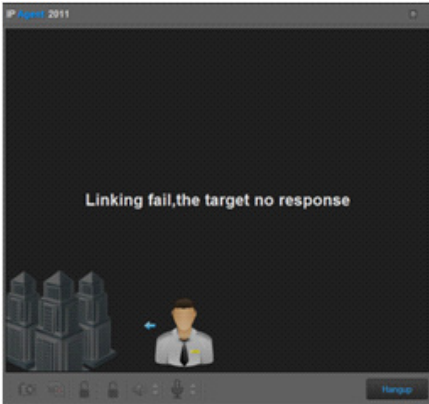

\* Incoming Call

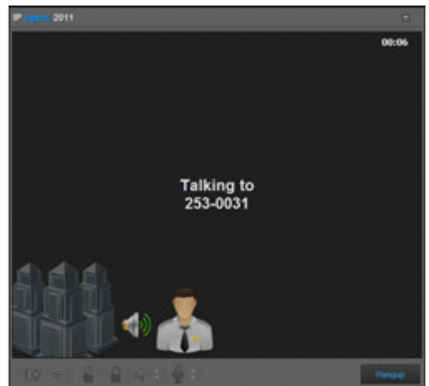
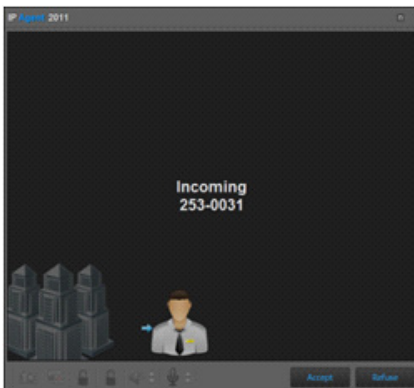

1) Press Accept to entry talking status, else press Refuse to deny the calling

2) Talking established after accept the calling, you can press Handup button to end the conversation

## b. DS & CDS

All the door stations & common door stations are listed in this frame.

\* Search one DS/CDS

You can input full or part of a device name to search one DS or CDS in the Search input box.

You can call or monitor DS or CDS in the DS & CDS frame

\* CALL

Press  button to call the related DS or CDS, then it will pop up a window for video and operation

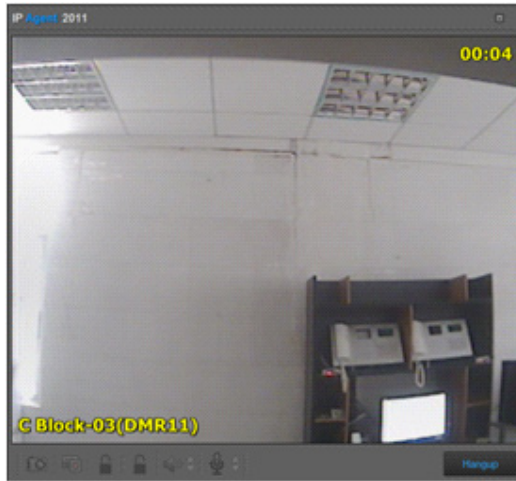

\* Incoming Call

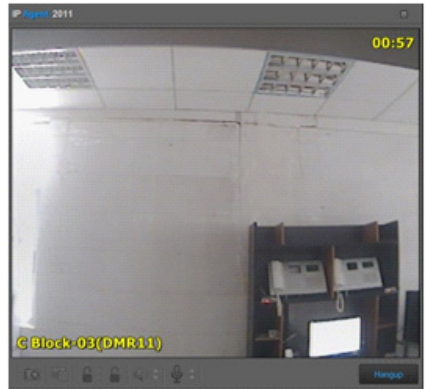
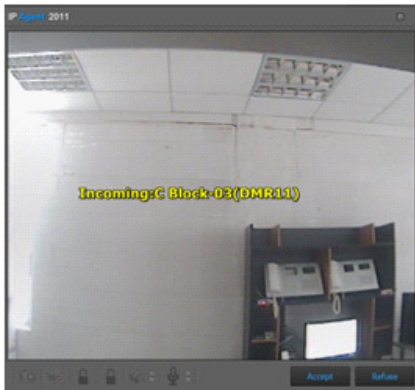

1) Press Accept to entry talking status, else press Refuse to deny the calling

2) Talking established after accept the calling, you can press Handup button to end the conversation

\* Monitoring DS/CDS

Press  button to monitor the related DS or CDS. The video will be shown in the focused monitor window.

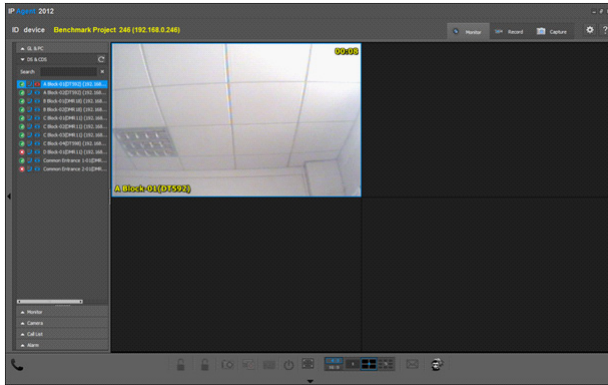

All the monitors of one selected building are listed in this frame.

### c. Monitor

\* Search a user

- 1) Click Building box and Select the related building
- 2) Input full or part of a monitor name in the Search input box

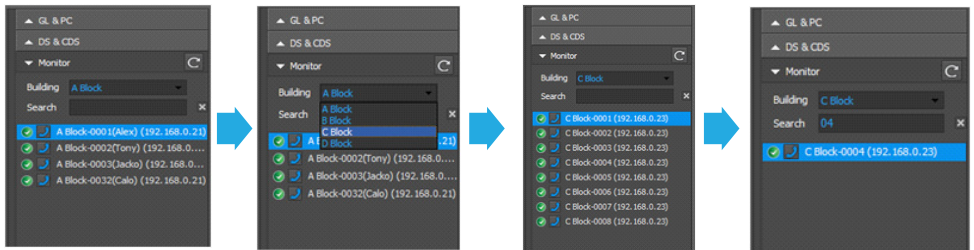

Press button to call the selected monitor, then it will pop up a window for calling

\* Call when no IP Camera

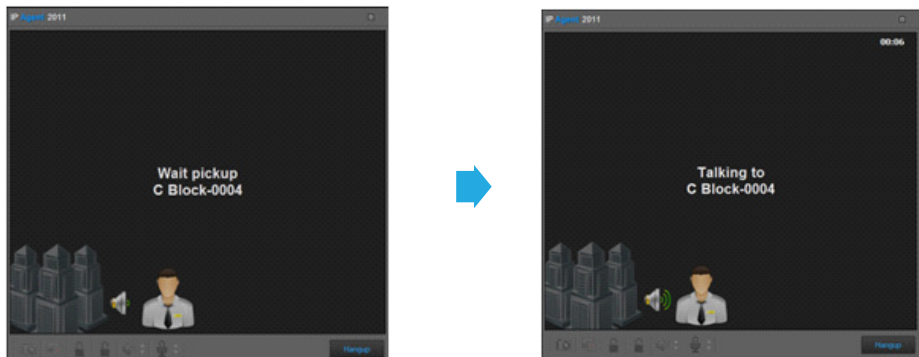

1) Call and wait for picking up

2) Talking established if the called monitor picks up



\* Call when IP Camera connected

If IP Camera function is activated by setting\*, video of IP Camera will be transmitted to IP-Agent and the called monitor simultaneously.

\*Details refer to SETTING Chapter

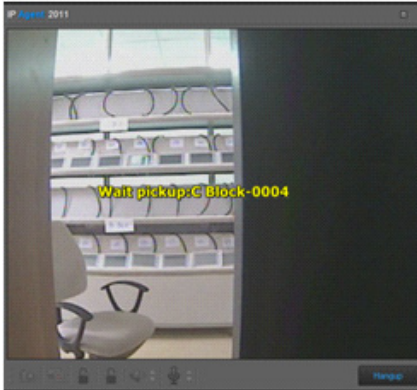

1) Call and wait for picking up



2) Talking established if the called monitor picks up

\* Incoming Call

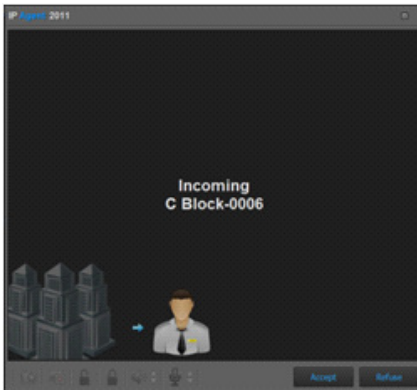

1) Press Accept to entry talking status, else press Refuse to deny the calling

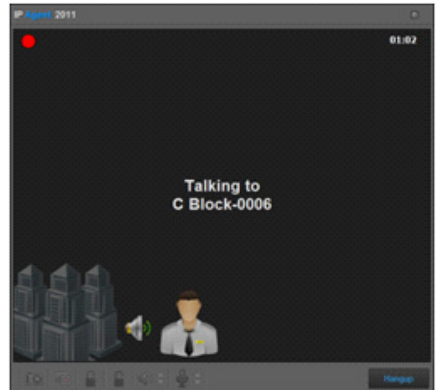

2) Talking established after accept the calling, you can press Handup button to end the conversation

## d. Camera

You can connect one camera to IP Network via CM-IPC.  
Press to view the network camera

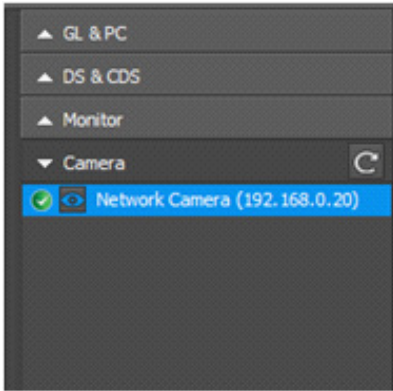

## Call List

Click the Call List tab to unfold the lists.

Call List is a record that includes call destination/call source, date, time and length of time

\* Icons & Description of Sub Lists

1. (All Call): All call info including outgoing calls, incoming call, missed calls
2. (Calls): Outgoing call info
3. (Incomings): Incoming call info
4. (Missed calls): Missed call info

Double click one record to call the related destination

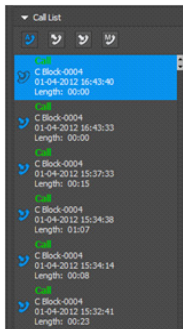

1.All Calls

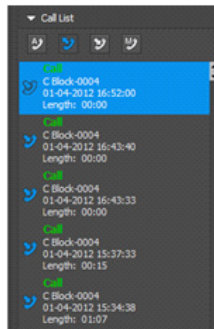

2.Outgoing calls

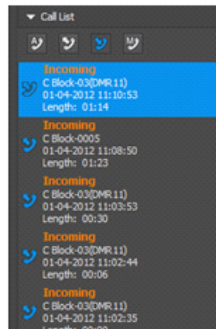

3.Incoming calls

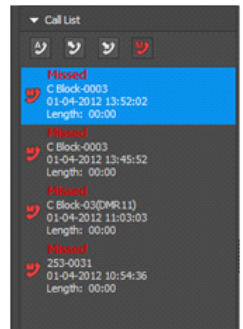

4.Missed calls

### 3.3.4 Record Viewer

From the top right corner of the IP-Agent main screen, click the [Record] tab.

#### Name and Function of each Item in Record View

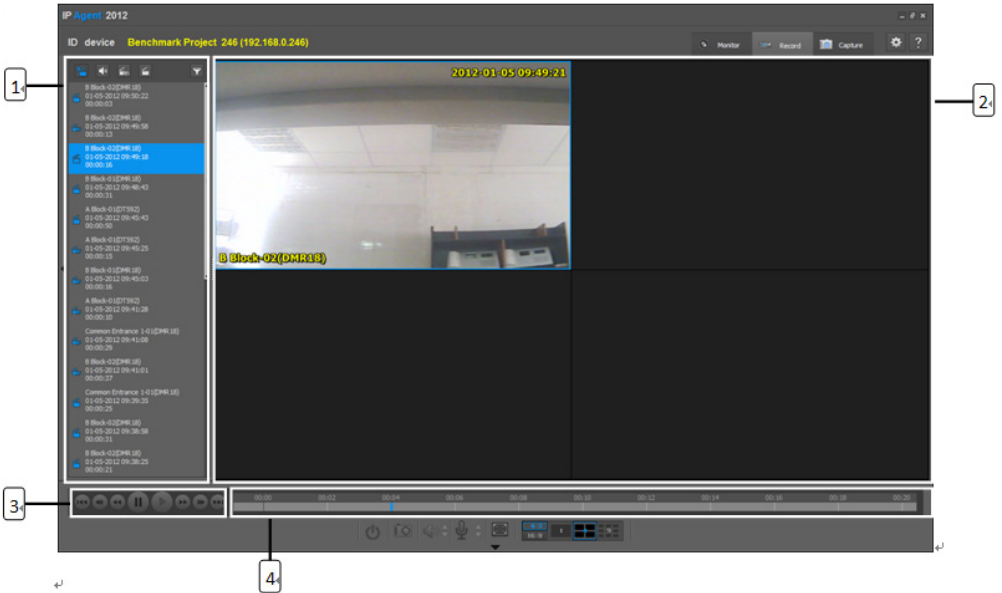

Item	Name	Description
1	Record List	Includes audio record, video record and talking record
2	Video Screen	Displays video/audio record
3	Record Controller	Controls record playing
4	Progress Bar	Shows the playing progress when playing record

## Name and Function of each Item in the Record Window



Item	Name	Description
1	Device Name	Displays the recorded device name
2	Record Time	Displays the time when the video/audio was recorded

### Record List



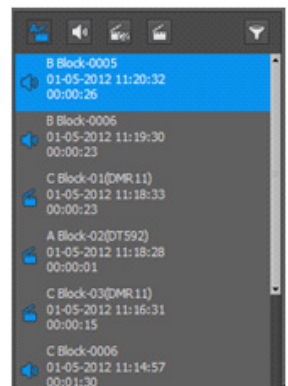

Record operation will be activated in the following cases:

1. Incoming calls from DS/CDS or monitor and respond the calls
2. Call DS/CDS or monitor and Auto Recording On Call function has been activated by setting\*1
3. Monitor DS/CDS and Auto Recording On Monitor function has been activated by setting\*2

\*1 & \*2: Details refer to Setting Chapter



## Icons & Description

1.  (All Record): All record including audio record, video record and talk record
2.  (Audio Record): Audio record for conversation between IP-Agent and monitor(based on setting), no video
3.  (Video Record): Video record for DS/CDS when monitoring(based on setting) , no audio
4.  (Talk Record): Talk record for conversation with video
5.  (Record Filter): Filter record by specific time and address

Double click to select one record to display in the video screen. As you see, more than one record can display in the video screen simultaneously, the number of displaying videos is up to the split number of the screen.



### 3.3.5 Capture Viewer

#### Name and Function of each Item in the Capture Viewer

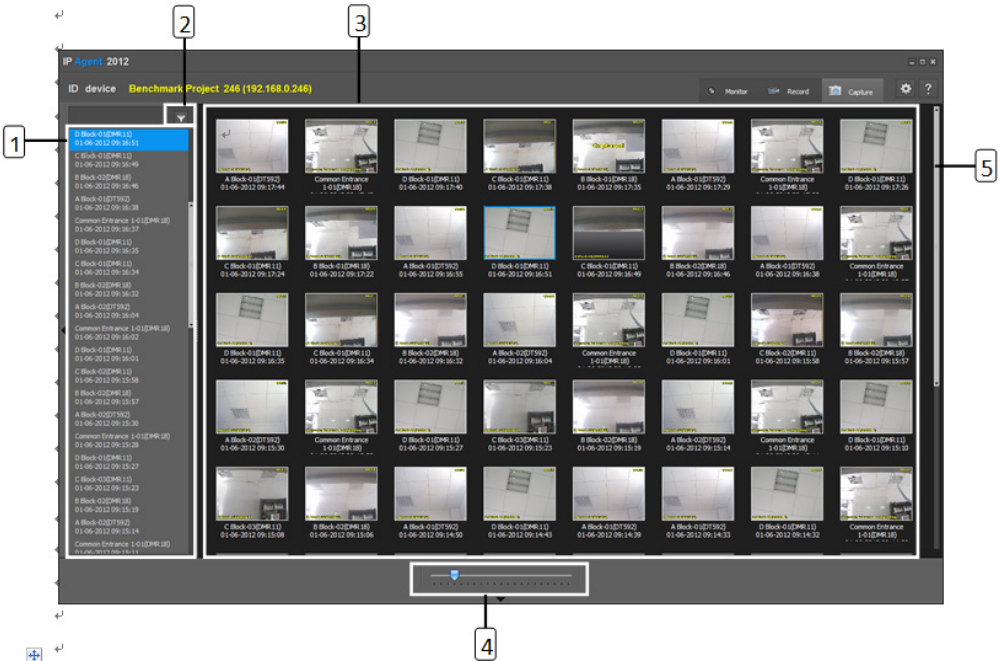

Item	Name	Description
1	Captured Picture List	Click to select the specific picture
2	Record Filter	Filter record by specific time and address
3	Video Screen	Displays captured pictures
4	Slide bar	Slide to adjust the number of pictures that can be viewed simultaneously in the video screen
5	Scroll bar	Slide to browse other pictures

## To View Big Picture

1. Select one picture in the captured picture list.
2. Double click the selected picture, then video screen will turn to big picture mode from browse mode.

### 1) Browse mode

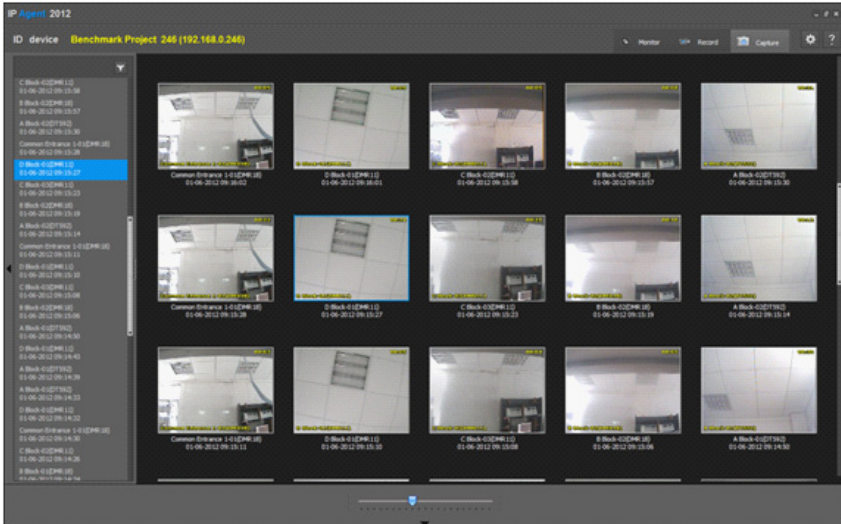

### 2) Big picture mode

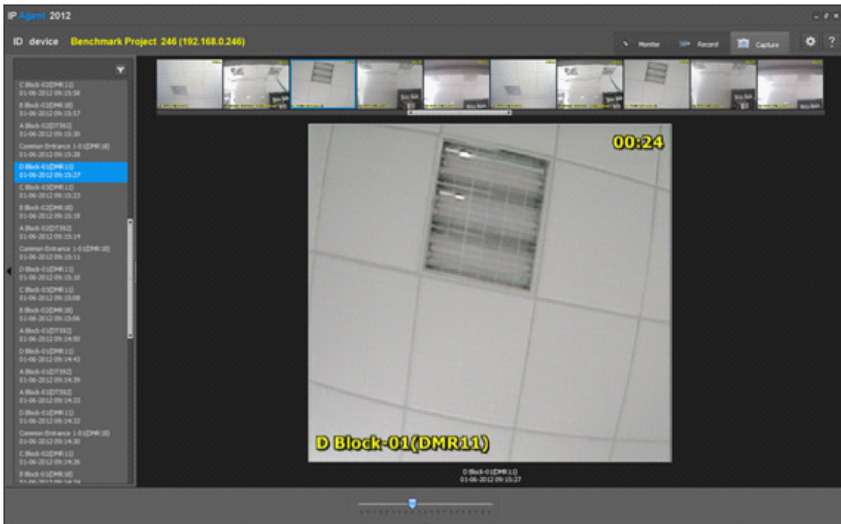

If you want to back to browse mode, just double click on one picture in the video screen

### 3.3.6 Setting

From the top right corner of the IP-Agent main screen, click the  button to entry setting page.

#### a. General

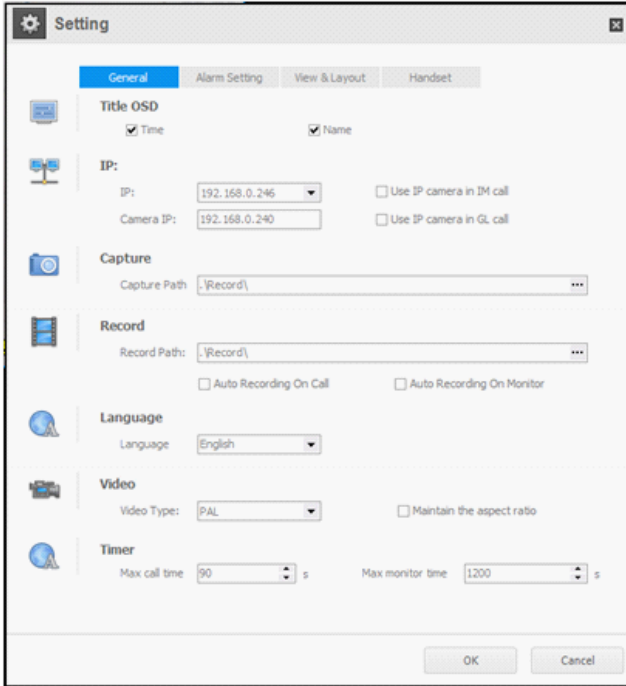

**Setting**

General | Alarm Setting | View & Layout | Handset

**Title OSD**

Time  Name

**IP:**

IP: 192.168.0.246  Use IP camera in IM call

Camera IP: 192.168.0.240  Use IP camera in GL call

**Capture**

Capture Path: {Record}

**Record**

Record Path: {Record}

Auto Recording On Call  Auto Recording On Monitor

**Language**

Language: English

**Video**

Video Type: PAL  Maintain the aspect ratio

**Timer**

Max call time: 90 s Max monitor time: 1200 s

OK Cancel



#### Title OSD

**Time:** Show time in video window when monitoring or calling

**Name:** Show device name in video window when monitoring or calling



#### IP

**IP:** Select the local machine address

**Camera IP:** Input IP Address of IP-Agent camera

**Use IP Camera in IM call:** Transmit video of IP-Agent camera to the called monitor

**Use IP Camera in GL call:** Transmit video of IP-Agent camera to the called Guard Center



#### Capture

**Capture Path:** Select a path to save all captured pictures





## Record

**Record Path:** Select a path to save all record documents

**Auto Recording On Call:** Activate auto recording when IP-Agent call devices

**Auto Recording On Monitoring:** Activate auto recording when monitoring devices



## Language

**Language:** English or Chinese(Simplified) optional



## Video

**Video Type:** PAL or NTSC optional

**Maintain the aspect ratio:** Maintain the aspect ratio or not



## Timer

**Max call time:** To set max call waiting time

**Max monitor time:** To set max monitor time for monitoring

## b. Alarm Setting

Reserved function for 2 wire system

## c. View & Layout

**Setting**

General Alarm Setting **View & Layout** Handset

**Channel On Start**

Layout: 16:9 Channel Number: 6

Enable Max Channel

**Monitor On Start**

Channel 1	8 Block-02[DMR 18]	Channel 2	
Channel 3		Channel 4	
Channel 5		Channel 6	
Channel 7		Channel 8	
Channel 9		Channel 10	
Channel 11		Channel 12	

**View**

Show IP  Auto Collaps List  Auto Size List

OK Cancel



**Channel On Start** : To set initial aspect ratio and split number of the video screen when IP-Agent gets start

**Layout**: To set initial aspect ratio for video screen when IP-Agent gets start

**Channel Number**: To set initial channel number for video screen when IP-Agent gets start

**Enable Max Channel**: Deselect the option to disable 9 and 12 channel selection in the main frame



**Monitor On Start**: To select specific DS/CDS to monitor automatically when IP-Agent gets start



**View**: Device list display setting

**Show IP**: Deselect the option to hide IP address of devices

**Auto Collaps List**: To set display format of device list, call list & alarm list. You can unfold more than one list in the frame if deselecting the option. If not, you just can unfold one list, previous unfolded list will be folded automatically if you unfold a new list.

**Auto Size List**: Disable this option if deselect Auto Collaps List. If select Auto Collaps List & then select the option, list will be unfolded to max size.

#### d. Handset

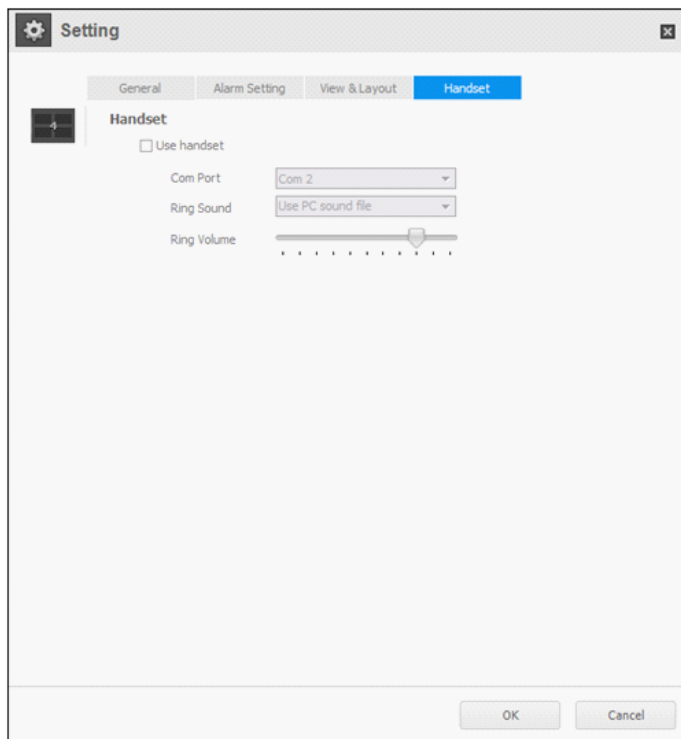

**Handset:** Add one handset to IP-Agent

**Use handset:** Enable a handset

**Com Port:** Select related com port for the connected handset

**Ring Sound:** Select a Ring Tone for handset

**Ring Volume:** Adjust Ring Volume for handset

# Appendix 1

## Prepare a IP network in DT system

All the setup is set in IP-Device software beside door station ID code setting, Monitor user code setting and DIP setting of DT-IPC.

### 1. Project Property

Project Name: TEST001  
Project Descriptions: Totally 4 blocks, 2 Common Entrances, 2 G3LV, 2 IP-Agent  
Project Remark: 2 wire system  
IP seg: 192.168.0.X

### 2. IP Node Config

Config the IP Node which will be used in this project

IP	Enable	Model	Device Name
192.168.0.20	yes	CM-IPC	Network Camera
192.168.0.21	yes	DT-IPC_DS	A Block
192.168.0.22	yes	DT-IPC_DS	B Block
192.168.0.23	yes	DT-IPC_DS	C Block
192.168.0.24	yes	DT-IPC_DS	D Block
192.168.0.25	yes	DT-IPC_CDS	Common Door Station 1
192.168.0.26	yes	DT-IPC_CDS	Common Door Station 2
192.168.0.240	yes	C5-IPC	Guard Unit Camera
192.168.0.243	yes	PC	Guard Station 3
192.168.0.244	yes	PC	Guard Station 4
192.168.0.253	yes	GL-IPC	Guard Station 2
192.168.0.254	yes	GL-IPC	Guard Station 1

### 3. Guard Centre Priority

Default GL Input	00
The Order of Default GL call transfer	
GL1	254(192.168.0.254)
GL2	253(192.168.0.253)
GL3	243(192.168.0.243)
GL4	244(192.168.0.244)
GL5	none
GL6	none
GL7	none
GL8	none

### 4. DS Config, Monitor Config and CDS Config

Why need config Door Station, monitor and common door station(CDS)

- 1) You have to config Door station(DS), monitor and common door station(CDS) before setup Input Table
- 2) Config DS, monitor and CDS for using IP-Agent
- 3) Can check DS, monitors and CDS if they are online

### 5. Input Table(For Global Room Input)

Why need Input Table?

Input table is a Global Room Input Table for DMR18(Common Door Station) to call all flats by using special input rules.

If default input rules can meet requirement, no necessary to setup Input Table(Default: IP + User Code).

IP	Address	Model	Device Name	CDS Input
192.168.0.21	1	DT59X	A Block-01(DT592)	
192.168.0.21	2	DT59X	A Block-02(DT592)	
192.168.0.21	0001	Monitor(DT)	A Block-0001(Slave)	001-01
192.168.0.21	0002	Monitor(DT)	A Block-0002(Slave)	001-02
192.168.0.21	0003	Monitor(DT)	A Block-0003(Slave)	001-03
192.168.0.21	0032	Monitor(DT)	A Block-00 or 32(Master)	001-00
192.168.0.22	1	DMR18	B Block-01	
192.168.0.22	2	DMR18	B Block-02	
192.168.0.22	0001	Monitor(DT)	B Block-0001	002-01
192.168.0.22	0002	Monitor(DT)	B Block-0002	002-02
192.168.0.22	0003	Monitor(DT)	B Block-0003	002-03
192.168.0.22	0004	Monitor(DT)	B Block-0004	002-04
192.168.0.22	0005	Monitor(DT)	B Block-0005	002-05
192.168.0.22	0006	Monitor(DT)	B Block-0006	002-06
192.168.0.22	0007	Monitor(DT)	B Block-0007	002-07
192.168.0.22	0008	Monitor(DT)	B Block-0008	002-08
192.168.0.23	1	DMR11S/D(ID)	C Block-01(DMR11)	
192.168.0.23	2	DMR11S/D(ID)	C Block-02(DMR11)	
192.168.0.23	3	DMR11S/D(ID)	C Block-03(DMR11)	
192.168.0.23	4	DT59X	C Block-04(DT598)	
192.168.0.23	0001	Monitor(DT)	C Block-0001	003-01
192.168.0.23	0002	Monitor(DT)	C Block-0002	003-02
192.168.0.23	0003	Monitor(DT)	C Block-0003	003-03
192.168.0.23	0004	Monitor(DT)	C Block-0004	003-04
192.168.0.23	0005	Monitor(DT)	C Block-0005	003-05
192.168.0.23	0006	Monitor(DT)	C Block-0006	003-06
192.168.0.23	0007	Monitor(DT)	C Block-0007	003-07
192.168.0.23	0008	Monitor(DT)	C Block-0008	003-08
192.168.0.24	1	DMR11S/D(ID)	D Block-01(DMR11/D8+EP24)	
192.168.0.24	0009	Monitor(DT)	D Block-0009	004-09
192.168.0.24	0010	Monitor(DT)	D Block-0010	004-10
192.168.0.24	0011	Monitor(DT)	D Block-0011	004-11

IP	Address	Model	Device Name	CDS Input
192.168.0.24	0012	Monitor(DT)	D Block-0012	004-12
192.168.0.24	0013	Monitor(DT)	D Block-0013	004-13
192.168.0.24	0014	Monitor(DT)	D Block-0014	004-14
192.168.0.24	0015	Monitor(DT)	D Block-0015	004-15
192.168.0.24	0016	Monitor(DT)	D Block-0016	004-16
192.168.0.24	0017	Monitor(DT)	D Block-0017	004-17
192.168.0.24	0018	Monitor(DT)	D Block-0018	004-18
192.168.0.24	0019	Monitor(DT)	D Block-0019	004-19
192.168.0.24	0020	Monitor(DT)	D Block-0020	004-20
192.168.0.24	0021	Monitor(DT)	D Block-0021	004-21
192.168.0.24	0022	Monitor(DT)	D Block-0022	004-22
192.168.0.24	0023	Monitor(DT)	D Block-0023	004-23
192.168.0.24	0024	Monitor(DT)	D Block-0024	004-24
192.168.0.25	1	DMR18	Common Door Station 1(DMR18)	
192.168.0.26	1	DMR11S/D(ID)	Common Door Station 2(DMR11)	
192.168.0.243		PC	Guard Station 3(IP-Agent)	000-03
192.168.0.244		PC	Guard Station 4(IP-Agent)	000-04
192.168.0.253		GL-IPC	Guard Station 2(G3LV)	000-02
192.168.0.254		GL-IPC	Guard Station 1(G3LV)	000-01

When using Direct Button Door Station

### **DMR11+EP11**

Specify each button to call IM or Guard Station

Note: 4 can be used, but code and target relation is fixed for all 4 DS in this IPC

Layout Map      Add: Different model combination of DMR11 S/D + EP S/D

## **6. Block Setup**

### **Network Camera(192.168.0.20)**

## A Block(192.168.0.21)

### General Description:

- 1) 2DS and 4 IM, use DT592 model
- 2) 1st button in DT592 call all IM. 2nd button call default Guard Unit(Default GL).
- 3) User Namelist in IM to call Guard Station

### IM Description:

- 1) Totally 4 IM in this block whose user codes are from 00 to 03
- 2) [16] in Namelist to call Default GL, [17] to call Guard Station 2(192.168.0.253), [18] to call Guard Station 3(192.168.0.243)

### DS Description:

- 1) 2 DS, their ID codes : 00 and 01
- 2) 1st button to call all IM, 2nd button to call Default GL

**Call Table Setup:** A Block -> right Click then select Management -> Select Call Table -> Select Button Call Table -> Select View & Edit

Edit **Button Call Map** table:

Index	Device Name	IP	Adress
16	Default GL	192.168.0.254	FFFF
17	Guard Station 2(G3LV)	192.168.0.253	
18	Guard Station 3(IP-Agent)	192.168.0.243	

Press **Write to Device** to download the setup to DT-IPC(192.168.0.21) after finished

## B Block(192.168.0.22)

**General Description:** 2 DS and 8 IM, use DMR18 model

### IM Description:

- 1) User codes of 8 IM are from 01 to 08
- 2) [00] in Namelist to call Default GL, [31] to call Guard Station 2(192.168.0.253), [30] to call Guard Station 3(192.168.0.243)

### DS Description:

- 1) 2 DMR18, ID code: 00 and 01
- 2) Input 32 to call Default GL, 31 to call Guard Station 2(192.168.0.253), 30 to call Guard Station 3(192.168.0.243)

**Call Table Setup:** A Block -> right Click then select Management -> Select Call Table -> Select Button Call Table -> Select View & Edit



Edit **Button Call Map** table:

Index	Device Name	IP	Adress
32	Default GL	192.168.0.254	FFFF
31	Guard Station 2(G3LV)	192.168.0.253	
30	Guard Station 3(IP-Agent)	192.168.0.243	

Press **Write to Device** to download the setup to DT-IPC(192.168.0.22) after finished

### **C Block(192.168.0.23)**

**General Description:** 4 DS and 8 IM, use DMR11 and DT598 model

#### **IM Description:**

- 1) User codes of IM are from 01 to 08
- 2) [09] in Namelist to call Default GL, [10] to call Guard Station 2(192.168.0.253), [11] to call Guard Station 3(192.168.0.243)

#### **DS Description:**

- 1) 3 DMR11 and 1 DT598, ID code: 00,01,02,03
- 2) Press 09 to call Default GL, 10 to call Guard Station 2(192.168.0.253), 11 to call Guard Station 3(192.168.0.243)

**Call Table Setup:** A Block -> right Click then select Management -> Select Call Table -> Select Button Call Table -> Select View & Edit

Edit **Button Call Map** table:

Index	Device Name	IP	Adress
09	Default GL	192.168.0.254	FFFF
10	Guard Station 2(G3LV)	192.168.0.253	
11	Guard Station 3(IP-Agent)	192.168.0.243	

Press **Write to Device** to download the setup to DT-IPC(192.168.0.23) after finished

### **D Block(192.168.0.24)**

**General Description:** 1 DMR11 + EP24 and 16 IM

#### **IM Description:**

- 1) User codes of IM are from 09 to 24
- 2) [00] in Namelist to call Default GL, [31] to call Guard Station 2(192.168.0.253), [30] to call Guard Station 3(192.168.0.243)

**DS Description:**

1) 1 DMR11/8 + EP24, ID code: 00

2) Press 32 to call Default GL, 31 to call Guard Station 2(192.168.0.253), 30 to call Guard Station 3(192.168.0.243)

**Call Table Setup:** A Block -> right Click then select Management -> Select Call Table -> Select Button Call Table -> Select View & Edit

Edit **Button Call Map** table:

Index	Device Name	IP	Adress
32	Default GL	192.168.0.254	FFFF
31	Guard Station 2(G3LV)	192.168.0.253	
30	Guard Station 3(IP-Agent)	192.168.0.243	

Press **Write to Device** to download the setup to DT-IPC(192.168.0.24) after finished

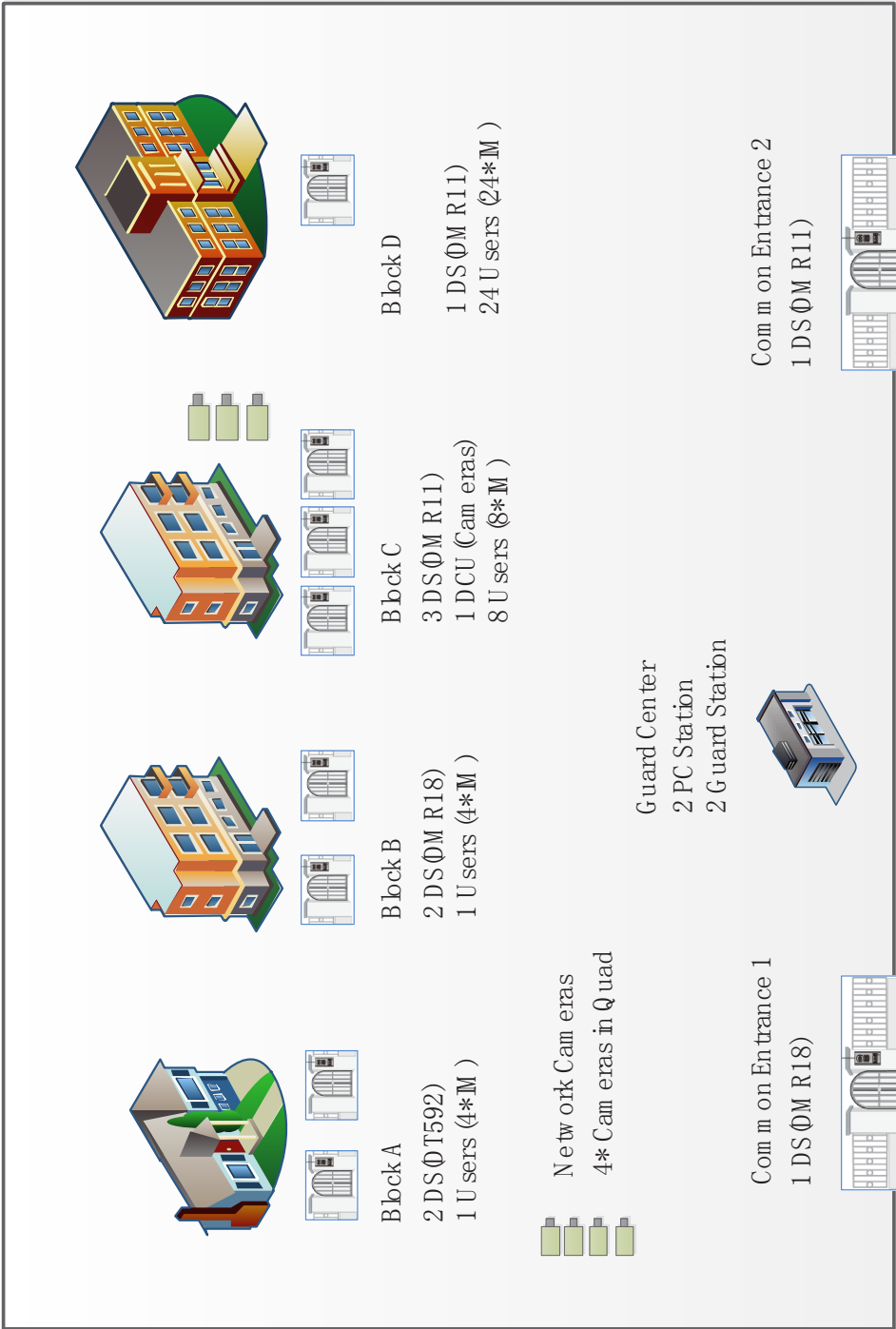

# Appendix 2

## System Design Process

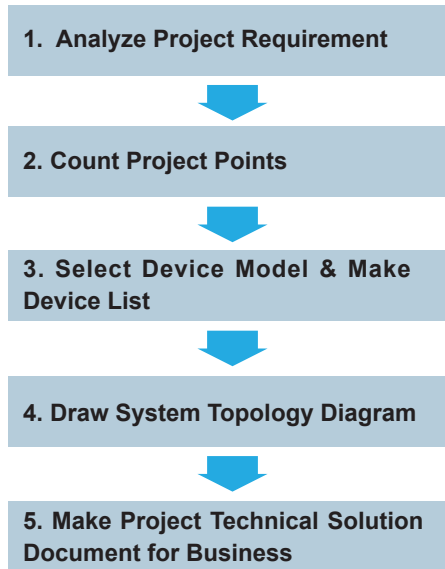

There are 3 buildings including one villa, two apartments. And there are one common entrance, 2 Switchboard including 1 PC station & 1 guard station in these residential complexes. In this application, a door entry system with the features below is required:

### 1. Analyze Project Requirement

- 1) It requires a networked connection among these 3 buildings, so that the security room can manage the residential complexes, e.g. call each flats and receive calling from each flats.
- 2) 1 common door station before the common entrance is needed and visitor can call the resident for unlock.
- 3) A video outdoor station with ID proximity card reader shall be installed in each building. It must be vandal proof.
- 4) Construct an IP DEDICATED network to allow long distance transmission and multi-channel communication to avoid communication block in the network like 2 Switchboards can call different buildings respectively at the same time.
- 5) One indoor monitor with image memory function shall be installed in each flat.
- 6) Any indoor monitor can call each other and at least 7" screen is required for good picture quality.

## 2. Count Project Points

All the above requirement can be met by 2-Easy intercom system.

Building	No. of floors for 1 building	No. of flats on each floor	Total flats	IM	Distributor	Power supply	Gateway	DS
A Block	/	/	1	4	1	1	1	1
B Block	8	2	16	16	4	1	1	1
C Block	6	4	24	24	7	1	1	2
Total			41	44	12	3	3	4

## 3. Select Device Model & Make Device List

### Apartment Device

Series	Name	Model	Qty	Unit	Remark
1	Door Station	DMR18	3	PC	For B & C blocks
2	Door Station	DT592	1	PC	For A block
3	Monitor	DT27SD	44	PC	with memory function
4	Distributor	DT-DBC4S	12	PC	One out of them connects multi-door stations in C Block
5	Power Supply	PS5-24V	3	PC	1 power supply feeds one building
6	Gateway	DT-IPC	3	PC	

### Network Device

Series	Name	Model	Qty	Unit	Remark
1	Guard Station	IP-G21	1	PC	Total 2 Switchboards
2	PC with PC Station	/	1	PC	
3	Common Door Station	DMR18	1	PC	1
4	Power Supply	PS5-24V	2	PC	One PS5 feeds one G21 and the other feeds common door station
5	Gateway	DT-IPC	1	PC	For Common Door Station
6	Network Switch	/	/	PC	The quantity of switch depends on project installation

## System Wires

Series	Name	Model	Qty	Unit	Remark
1	Wire for Apartment riser connection	Twisted Cable	/	Meter	Using twisted cable to connect riser devices in apartments. 2*1.0mm <sup>2</sup> or 2*1.5 mm <sup>2</sup> is recommended
2	Wire for Network Connection	CAT5	/	Meter	Connect to gateway, Switchboard and network switch

# 4. System Topology Diagram

